

PROFESSIONAL DIGITAL TWO-WAY RADIO SYSTEM



MOTOTRBO™ REPEATER BASIC SERVICE & INSTALLATION MANUAL

SLR 5000 SERIES



en-US

fr-CA

Notice

Foreword

This manual covers all versions of the MOTOTRBO SLR 5000 Series Repeater, unless otherwise specified. It includes all the information necessary to maintain peak product performance and maximum working time, using levels 1 and 2 maintenance procedures. This level of service goes down to the module replacement level and is typical of some local service centers, Motorola Solutions Authorized Dealers, self-maintained customers, and distributors.



CAUTION: These servicing instructions are for use by qualified personnel only. To reduce the risk of electric shock, do not perform any servicing other than that contained in the Operating Instructions unless you are qualified to do so. Refer all servicing to qualified service personnel.

General Safety Precautions

For more information, see [General Safety and Installation Standards and Guidelines on page 5](#).

Computer Software Copyrights

The Motorola Solutions products described in this manual may include copyrighted Motorola Solutions computer programs stored in semiconductor memories or other media. Laws in the United States and other countries preserve for Motorola Solutions certain exclusive rights for copyrighted computer programs, including, but not limited to, the exclusive right to copy or reproduce in any form the copyrighted computer program. Accordingly, any copyrighted Motorola Solutions computer programs contained in the Motorola Solutions products described in this manual may not be copied, reproduced, modified, reverse-engineered, or distributed in any manner without the express written permission of Motorola Solutions. Furthermore, the purchase of Motorola Solutions products shall not be deemed to grant either directly or by implication, estoppel, or otherwise, any license under the copyrights, patents or patent applications of Motorola Solutions, except for the normal non-exclusive license to use that arises by operation of law in the sale of a product.

Document Copyrights

No duplication or distribution of this document or any portion thereof shall take place without the express written permission of Motorola Solutions. No part of this manual may be reproduced, distributed, or transmitted in any form or by any means, electronic or mechanical, for any purpose without the express written permission of Motorola Solutions.

Disclaimer

The information in this document is carefully examined, and is believed to be entirely reliable. However, no responsibility is assumed for inaccuracies. Furthermore, Motorola Solutions reserves the right to make changes to any products herein to improve readability, function, or design. Motorola Solutions does not assume any liability arising out of the applications or use of any product or circuit described herein; nor does it cover any license under its patent rights nor the rights of others. Controlled copies of this document is available via Motorola On-Line (MOL).

Trademarks

MOTOROLA, MOTO, MOTOROLA SOLUTIONS and the Stylized M logo are trademarks or registered trademarks of Motorola Trademark Holdings, LLC and are used under license. All other trademarks are the property of their respective owners.

© 2016 Motorola Solutions, Inc.

All rights reserved.

Notice

General Safety and Installation Standards and Guidelines



WARNING:

- For safe installation, operation, service and repair of this equipment, follow the safety precautions and instructions described below, as well as any additional safety information in Motorola Solutions product service and installation manuals and the Motorola Solutions R56 Standards and Guidelines for Communications Sites manual (which can be obtained by ordering CDROM 9880384V83). To obtain copies of these materials, please contact Motorola Solutions as directed at the end of this section. After installation, these instructions should be retained and readily available for any person operating or servicing this repeater or working near it.
- Failure to follow these safety precautions and instructions could result in serious injury or property damage.
- The installation process requires preparation and knowledge of the site before installation begins. Review installation procedures and precautions in the Motorola Solutions R56 manual before performing any site or component installation. Personnel must use safe work practices and good judgment, and always follow applicable safety procedures, such as requirements of the Occupational Safety and Health Administration (OSHA), the National Electrical Code (NEC), and local codes.



The following are additional general safety precautions that must be observed:

- To continue compliance with any applicable regulations and maintain the safety of this equipment, do not install substitute parts or perform any unauthorized modifications.
- All equipment must be serviced by Motorola Solutions trained personnel.
- If troubleshooting the equipment while the power is on, be aware of live circuits which could contain hazardous voltage.
- Do not operate the radio transmitters unless all RF connectors are secure and all connectors are properly terminated.
- All equipment must be properly grounded in accordance with the Motorola Solutions R56 and specified installation instructions for safe operation.
- Slots and openings in the cabinet are provided for ventilation. Do not block or cover openings that protect the devices from overheating.



- Some equipment components can become extremely hot during operation. Turn off all power to the equipment and wait until sufficiently cool before touching.
- Maintain emergency first aid kits at the site.
- Never store combustible materials in or near equipment racks. The combination of combustible material, heat and electrical energy increases the risk of a fire hazard. Equipment shall be installed in a site that meets the requirements of a "restricted access location," per (UL60950-1 & EN60950-1), which is defined as follows: "Access can only be gained by service persons or by users who have been instructed about the reasons for the restrictions applied to the location and about any precautions that shall be taken; and access is

through the use of a tool or lock and key, or other means of security, and is controlled by the authority responsible for the location."

-  Burn hazard. The metal housing of the product may become extremely hot. Use caution when working around the equipment.
-  RF energy burn hazard. Disconnect power in the cabinet to prevent injury before disconnecting and connecting antennas.
- Shock hazard. The outer shields of all Tx and Rx RF cables outer shields must be grounded per Motorola Solutions R56 manual.
- Shock hazard. DC input voltage shall be no higher than 60 VDC. This maximum voltage shall include consideration of the battery charging "float voltage" associated with the intended supply system, regardless of the marked power rating of the equipment.
- All Tx and Rx RF cables shall be connected to a surge protection device according to Motorola Solutions R56 manual. Do not connect Tx and Rx RF cables directly to an outside antenna.
-  **Attention** Compliance with National and International standards and guidelines for human exposure to Electromagnetic Energy (EME) at Transmitter Antenna sites generally requires that persons having access to a site shall be aware of the potential for exposure to EME and can exercise control of exposure by appropriate means, such as adhering to warning sign instructions. See this installation manual and Appendix A of Motorola Solutions R56.

This product complies with the requirements set forth by the European R&TTE regulations and applicable CENELEC standards concerning human exposure to Electromagnetic Energy (EME) at Transmitter Antenna sites. [Appendix F : MOTOTRBO Repeater – EME ASSESSMENT on page 155](#) in this manual includes an EME exposure analysis of a typical system configuration for this product.

For a different system configuration than the typical configuration, compliance with applicable EME exposure standards (current versions of the EN50384 and EN50385 standards for occupational and general public exposure, respectively) can be evaluated by either employing the method illustrated in the typical system configuration EME exposure analysis included in [Appendix F : MOTOTRBO Repeater – EME ASSESSMENT on page 155](#) in this manual, or employing another suitable method among those described in the current version of the EN50383 standard.

Once the occupational and general public compliance boundaries are determined, means to ensure that workers and people are outside the respective boundaries, for instance using appropriate signage or restricted access, should be implemented; if this is not possible or practically achievable for the specific system configuration, the configuration should be modified in order to make it possible. The R56 Standards and Guidelines for Communications Sites manual (which can be obtained by ordering CDROM 9880384V83) provides examples of signage that can be used to identify the occupational or general public compliance boundaries.

Refer to product specific manuals for detailed safety and installation instructions. Manuals can be obtained with product orders, downloaded from <https://businessonline.motorolasolutions.com>, or purchased through the Motorola Solutions Aftermarket & Accessory Department.



WARNING: This is a class A product. In a domestic environment, this product may cause radio interference in which case the user may be required to take adequate measures.

Notice

MOTOTRBO SLR 5000 Series Repeater Supplemental Safety and Installation Requirements



IMPORTANT:

- The MOTOTRBO SLR 5000 Series Repeater must be installed in a suitable, in-building enclosure. A restricted access location is required when installing this equipment into the end system.
- The repeater contains a Class 1 built-in power supply component. It is equipped with an appliance inlet for connecting to an AC input, as well as DC input terminals which meet SELV DC circuit requirements.
- When installing the equipment, all requirements of relevant standards and local electrical codes must be fulfilled.
- The maximum operating ambient temperature of this equipment is 60 °C. The maximum operating altitude is 2000 meters above sea level.
- The 13.6 VDC output from the power supply to the PA is at an energy hazard level (exceeds 240 VA). When installing into the end system, care must be taken so as not to touch the output wires.
- When the SLR 5000 Series Repeater is used in a DC reverting system, the DC power supply must be located in the same building as the MOTOTRBO SLR 5000 Series Repeater, and it must meet the requirements of a SELV circuit.

This page intentionally left blank.

Notice

Environmental Information

Material Content

**NOTICE:**

- The Motorola MOTOTRBO SLR 5000 Series Repeater system and its subsystems have been created in compliance with the environmental goals of the European Union's Restriction of Hazardous Substances (RoHS 2) Directive 2011/65/EU and the Waste Electrical and Electronic Equipment (WEEE) Directive 2012/19/EU as well as Motorola Solutions corporate goals to minimize environmental impact of its products.
- This Motorola Solutions policy is reflected throughout the entire design, procurement, assembly, and packaging process.
- In support of these efforts to provide environmentally-responsible products, please comply with the information in the following sections regarding product disposal for systems being replaced.

Disposal of your Electronic and Electric Equipment

Please do not dispose of electronic and electric equipment or electronic and electric accessories with your household waste. In some countries or regions, collection systems have been set up to handle waste of electrical and electronic equipment.

In European Union countries, please contact your local equipment supplier representative or service center for information about the waste collection system in your country.

Disposal Guideline

The following symbol on a Motorola Solutions product indicates that the product should not be disposed of with household waste.



This page intentionally left blank.

Document History

The following major changes have been implemented in this manual since the previous edition:

Edition	Description	Date
MN001436A01-AA	Initial Release	April 2015

This page intentionally left blank.

Contents

Document History	11
List of Figures	21
List of Tables	25
Summary of Bands Available	27
Chapter 1: SLR 5000 Series Repeater	33
1.1 Notations Used in This Manual.....	33
1.2 Description.....	33
1.3 Operating Features.....	35
1.4 Frequency Ranges and Power Levels.....	37
1.5 Specifications.....	37
1.6 Theory of Operation.....	39
1.7 Basic Repeater Level Troubleshooting – RDAC and LEDs.....	41
1.8 Repeater Model Numbering Scheme.....	43
1.9 Model Chart.....	43
1.9.1 VHF High Power.....	43
1.9.2 UHF1 High Power.....	44
Chapter 2: SLR 5000 Series Satellite Receiver	45
2.1 Description.....	45
2.2 Operating Features.....	45
2.3 Frequency Ranges.....	45
2.4 Specifications.....	45
2.5 Configuration.....	45
2.6 Basic Station Level Troubleshooting – RDAC and LEDs.....	46
2.7 Model Chart.....	46
Chapter 3: SLR 5000 Series Modem	47
3.1 Description.....	47
3.1.1 General Description.....	47
3.1.2 Input and Output Connections.....	47
3.1.3 Frequency Bands.....	49
3.2 Receiver Subsystem.....	49
3.2.1 Description.....	49
3.2.2 Specifications.....	49
3.3 Transmitter Exciter Subsystem.....	50
3.3.1 Description.....	50
3.3.2 Specifications.....	50

3.4 Station Control Subsystem.....	51
3.4.1 Description.....	51
3.4.2 High Stability Reference Block.....	51
3.4.3 Audio.....	52
3.5 Station Control Interface.....	52
3.5.1 Front Panel Interface Connector.....	52
3.5.2 Rear Panel Connections.....	52
3.5.3 Power Amplifier Interface Connector.....	52
3.5.4 Power Supply Interface Connector.....	53
3.5.5 Expansion Board Interface Connector.....	53
3.5.6 Chassis ID Interface Connector.....	53
Chapter 4: SLR 5000 Series Power Amplifier.....	55
4.1 Description.....	55
4.1.1 General Description.....	55
4.2 Input and Output Connections.....	55
4.3 Frequency Ranges.....	56
4.4 Specifications.....	56
4.5 Modem Interface.....	57
Chapter 5: SLR 5000 Series Power Supply.....	59
5.1 Description.....	59
5.1.1 General Description.....	59
5.2 Specifications.....	60
5.3 Power Supply Interface.....	61
5.3.1 Power Source Inputs.....	61
5.3.2 Power Supply Outputs.....	62
5.3.3 Power Supply Digital Interface.....	63
5.3.4 Power Supply Output Cable Signaling.....	63
Chapter 6: SLR 5000 Series Front Panel.....	65
6.1 Description.....	65
6.1.1 General Description.....	65
6.2 Input and Output Connections.....	65
6.3 Interfaces.....	66
6.3.1 Modem Interface.....	66
6.3.2 User/Service Interface.....	66
6.3.2.1 USB.....	66
6.3.2.2 LED Indicators.....	66
Chapter 7: SLR 5000 Series Back Panel.....	67
7.1 Description.....	67
7.1.1 General Description.....	67

7.2 Back panel Interfaces.....	68
7.2.1 AC Power Inlet.....	68
7.2.2 DC Power Inlet/DC Charger Outlet.....	69
7.2.3 Option 1/GNSS.....	69
7.2.4 Option 2/WLAN.....	69
7.2.5 USB.....	69
7.2.6 Ethernet 1.....	70
7.2.7 Ethernet 2.....	70
7.2.8 Auxiliary (Aux).....	71
7.2.9 Frequency Reference.....	74
7.2.10 Receiver RF.....	74
7.2.11 Transmitter RF.....	74
7.2.12 Bonding Ground Connection.....	75
Chapter 8: SLR 5000 Series Test Equipment And Service Aids.....	77
8.1 Recommended Test Equipment.....	77
8.2 Service Aids.....	77
Chapter 9: SLR 5000 Series Performance Check or Testing.....	79
9.1 General.....	79
9.2 Transmitter Testing.....	79
9.2.1 Introduction.....	79
9.2.2 Test Equipment.....	79
9.2.3 Verifying Transmitter Circuitry Procedure.....	80
9.3 Receiver Testing.....	81
9.3.1 Introduction.....	81
9.3.2 Required Test Equipment.....	81
9.3.3 Verifying Receiver Circuitry Procedure.....	82
9.4 Auto Test and Tune Support.....	83
Chapter 10: SLR 5000 Series Programming and Tuning.....	85
10.1 Introduction.....	85
10.2 Customer Programming Software Setup.....	85
10.3 Reference Oscillator Alignment.....	86
10.3.1 Tuning Procedure.....	86
10.4 Repeater Tuning Setup.....	87
10.5 Rx Audio Level Set.....	87
10.5.1 Tuning Procedure.....	87
10.6 Tx Audio Level Set.....	88
10.6.1 Tuning Procedure.....	88
10.7 Modulation Limit Alignment.....	89
10.7.1 Tuning Procedure (with no Tx Data and no PL).....	89

10.7.2 Verification (with no Tx Data and no PL).....	90
10.7.3 Tuning Procedure (with Tx Data or PL).....	91
10.7.4 Verification (with Tx Data or PL).....	92
10.8 Changing to Battery Charger Only Mode.....	92
Chapter 11: SLR 5000 Series Maintenance and Disassembly/Reassembly.....	93
11.1 Introduction.....	93
11.2 Routine Maintenance.....	93
11.3 Preventive Maintenance.....	93
11.3.1 Inspection.....	93
11.3.2 Cleaning Procedures.....	93
11.4 Safe Handling of CMOS and LDMOS Devices.....	94
11.5 Disassembly.....	95
11.5.1 Disassembly – General.....	95
11.5.2 Disassembly – Detailed.....	96
11.5.2.1 Protective Cover Disassembly.....	96
11.5.2.2 Front Housing Disassembly.....	96
11.5.2.3 Cable Disassembly.....	96
11.5.2.4 Fan Disassembly.....	97
11.5.2.5 Front Panel Disassembly.....	98
11.5.2.6 Power Supply Removal.....	98
11.5.2.7 Modem Removal.....	99
11.5.2.8 Power Amplifier Module Removal.....	99
11.5.2.9 Back Panel Removal.....	100
11.6 Assembly and Reassembly.....	101
11.6.1 Assembly – Detailed.....	101
11.6.1.1 Back Panel Installation.....	101
11.6.1.2 Input Cable Installation.....	102
11.6.1.3 Power Amplifier Module Installation.....	104
11.6.1.4 Modem Installation.....	104
11.6.1.5 Power Supply Installation.....	106
11.6.1.6 Fan Installation.....	107
11.6.1.7 Front Panel Installation.....	108
11.6.1.8 Cable Installation.....	108
11.6.1.9 Front Housing Installation.....	110
11.6.1.10 Protective Cover Installation.....	111
11.7 Exploded Mechanical View.....	111
11.8 Parts List.....	112
11.9 Torque Charts.....	113
Chapter 12: SLR 5000 Series Installation.....	115

12.1 Pre-Installation Considerations.....	115
12.1.1 Installation Overview.....	115
12.1.2 Site Environmental Conditions.....	115
12.1.3 Equipment Ventilation.....	116
12.1.3.1 Mounting the SLR 5000 Series Repeater in a Cabinet.....	116
12.1.3.2 Mounting the SLR 5000 Series Repeater in a Rack.....	116
12.1.4 AC and DC Input Power Requirements.....	117
12.1.4.1 AC Input Power Requirements.....	117
12.1.4.2 DC Input Power Requirements.....	117
12.1.4.3 Ground Connection.....	117
12.1.4.4 Battery Connection.....	117
12.1.4.5 RF Antenna Connections.....	118
12.1.4.6 System Cable Connections.....	118
12.1.5 Equipment Mounting Methods.....	118
12.1.5.1 Floor-Mounted Cabinet.....	118
12.1.5.2 Modular Racks.....	119
12.1.5.3 Desk Mount.....	120
12.1.6 Site Grounding and Lightning Protection.....	120
12.1.6.1 Electrical Ground.....	120
12.1.6.2 RF Ground.....	120
12.1.6.3 Lightning Ground.....	121
12.1.6.4 Equipment Grounding.....	121
12.1.7 Recommended Tools and Equipment.....	121
12.1.8 Equipment Unpacking and Inspection.....	121
12.1.8.1 Unpacking Equipment.....	121
12.1.8.2 Initial Inspection.....	121
12.2 Mechanical Installation.....	122
12.2.1 Equipment Unpacking and Inspection.....	122
12.2.2 Mounting Procedures.....	122
12.2.2.1 Transferring Equipment from Shipping Container to Rack or Cabinet...	122
12.2.2.2 Installing Racks.....	123
12.2.2.3 Installing Cabinets.....	123
12.2.2.4 Desk Mount.....	124
12.3 Electrical Connections.....	124
12.3.1 Power Supply Connections.....	125
12.3.1.1 AC Input Power Connection.....	125
12.3.1.2 DC Input Power Connection/ DC Charger Connection.....	126
12.3.1.3 Ground Connection.....	126
12.3.1.4 Battery Connection.....	126

12.3.1.5 RF Antenna Connections.....	126
12.3.1.6 System Cable Connections.....	126
12.4 Post Installation Checklist.....	127
12.4.1 Applying Power.....	127
12.4.2 Verifying Proper Operation.....	127
12.4.3 Front Panel LEDs.....	127
12.4.4 Copying the Repeater Codeplug Data to a Computer.....	127
12.5 Installing Repeater Hardware Options.....	127
12.5.1 General Bonding and Grounding Requirements.....	127
12.5.2 General Cabling Requirements.....	128
Appendix A : Accessories.....	129
Introduction.....	129
Cables.....	129
Documentation.....	129
Duplexers.....	129
Mounting.....	130
Preselectors.....	130
Service Parts.....	130
Service Tools.....	131
Appendix B : Replacement Parts Ordering.....	133
Replacement Parts Ordering.....	133
Basic Ordering Information.....	133
Motorola Online.....	133
Mail Orders.....	133
Telephone Orders.....	133
Fax Orders.....	133
Parts Identification.....	134
Product Customer Service.....	134
Appendix C : Motorola Service Centers.....	135
Motorola Service Centers.....	135
Servicing Information.....	135
Motorola Service Center.....	135
Motorola Federal Technical Center.....	135
Motorola Canadian Technical Logistics Center.....	135
Appendix D : SLR 5000 Series Third-Party Controllers.....	137
Overview.....	137
Community Repeater Panel.....	137
Description.....	137
Compatibility.....	138

Hardware Connections.....	138
CPS Configuration.....	139
Community Repeater Panel Settings.....	140
Discriminator.....	141
Tx Audio.....	141
Continuous Tone-Controlled Squelch Systems (CTCSS) Out.....	141
Tx Audio Pre-Emphasis.....	141
Carrier Operated Relay (COR).....	141
Phone Patch.....	141
Description.....	141
Compatibility.....	142
Hardware Connections.....	142
CPS Configuration.....	143
Phone Patch Level Settings.....	144
Disc.....	144
Tx Audio.....	144
CTCSS/ DCS DECODE INPUT/ COR.....	144
Tone Remote Adapter.....	144
Description.....	144
Compatibility.....	145
Hardware Connections.....	145
CPS Configuration (For a 15 Channel Remote Control).....	146
Tone Remote Adapter settings.....	147
Radio Rx.....	147
Radio Tx.....	148
Channel Steering.....	148
Monitoring.....	148
PTT.....	148
Wildcard 1 (optional).....	148
Trunking Controllers.....	148
Description.....	148
Compatibility.....	149
Hardware Connections.....	149
CPS Configuration.....	150
Trunking Controller Settings.....	151
Discriminator.....	151
Tx Audio.....	151
Tx Data.....	151
Appendix E : Audio Enhancement.....	153

- Overview..... 153
 - Hear Clear feature with the third party controllers..... 153
 - Third party controller and the subscriber configuration for Hear Clear feature..... 153
 - Hear Clear feature configuration in repeater mode..... 153
 - Companding feature configuration between third party controllers and subscriber..... 154
 - Companding feature configuration between the repeater and subscribers..... 154
- Appendix F : MOTOTRBO Repeater – EME ASSESSMENT..... 155**
 - Executive Summary..... 155
 - Exposure Prediction Model..... 155
 - Exposure in Front of the Antenna..... 155
 - Exposure at Ground Level..... 157
 - Typical System Configuration..... 158
 - Exposure Limits..... 158
 - EME Exposure Evaluation..... 158
 - Exposure in Front of the Antenna..... 158
 - Exposure at Ground Level..... 159
 - Compliance Boundary Description..... 159
 - Product Put In Service..... 159
 - References..... 160
- Glossary of Terms and Acronyms..... 161**

List of Figures

Figure 1: Front view of the SLR 5000 Series Repeater.....	34
Figure 2: Rear view of the SLR 5000 Series Repeater.....	34
Figure 3: Front view (without top cover) of the SLR 5000 Series Repeater.....	35
Figure 4: Front view (without top and bottom covers and front panel) of the SLR 5000 Series Repeater.....	35
Figure 5: RDAC Diagnostic Screen.....	41
Figure 6: Repeater Model Numbering Scheme.....	43
Figure 7: “Operation Mode” configuration for Satellite Receiver Functionality.....	46
Figure 8: Modem Module Connector Locations.....	48
Figure 9: High Stability Reference Circuit.....	51
Figure 10: Audio Block Diagram.....	52
Figure 11: Power Amplifier Interface Connector Pin Locations.....	53
Figure 12: Power Supply Interface Connector Pin Locations.....	53
Figure 13: Expansion Board Interface Connector Pin Locations.....	53
Figure 14: Chassis ID Interface Connector Pin Locations.....	54
Figure 15: Input and Output Connections.....	56
Figure 16: Modem Interface Connector Pin Locations.....	57
Figure 17: Front View of the SLR 5000 Series Power Supply.....	60
Figure 18: Rear View of the SLR 5000 Series Power Supply.....	60
Figure 19: Power Source Inputs.....	61
Figure 20: Power Supply Outputs.....	62
Figure 21: Power Supply Digital Interface.....	63
Figure 22: Front Panel Input and Output Connections.....	65
Figure 23: Back Panel Connector Names and Locations.....	67
Figure 24: AC Power Inlet Connector	68
Figure 25: Repeater Power Switch.....	68
Figure 26: DC Power Inlet/DC Charger Outlet Connector.....	69
Figure 27: Option 1/GNSS Connector.....	69
Figure 28: Option 2/WLAN Connector.....	69
Figure 29: USB Connector.....	70
Figure 30: Ethernet 1 Connector.....	70
Figure 31: Ethernet 2 Connector.....	71
Figure 32: Auxiliary Connector.....	71
Figure 33: Frequency Reference Connector.....	74
Figure 34: Receiver RF Connector.....	74
Figure 35: Transmitter RF Connector.....	75

Figure 36: Bonding Ground Connection.....	75
Figure 37: Test Equipment Setup for Verifying Transmitter Circuitry.....	81
Figure 38: Test Equipment Setup for Verifying Receiver Circuitry.....	83
Figure 39: Customer Programming Software Setup.....	85
Figure 40: Front view of SLR 5000 Series Repeater.....	86
Figure 41: Rear view of SLR 5000 Series Repeater.....	86
Figure 42: Tx Menu Tree (Ref. Oscillator).....	87
Figure 43: SLR 5000 Series Repeater Tuning Equipment Setup.....	87
Figure 44: Rx Menu tree (Rx Rated Volume).....	88
Figure 45: Auxiliary Connector.....	88
Figure 46: Tx Menu Tree (Tx Audio Level).....	89
Figure 47: Tx Menu tree (Tuning Procedure with no Tx data).....	90
Figure 48: Example of maximum deviation limit calculation.....	91
Figure 49: Removing Front Housing from Repeater.....	96
Figure 50: Removing Cables.....	97
Figure 51: Removing Fan.....	98
Figure 52: Removing Front Panel.....	98
Figure 53: Removing Power Supply Module from Repeater.....	99
Figure 54: Removing Modem.....	99
Figure 55: Removing Power Amplifier Module.....	100
Figure 56: Removing Rx and REF BNC Cables.....	100
Figure 57: Removing Ground Screw.....	101
Figure 58: Installing M3 Screws.....	102
Figure 59: Installing M6 Screw.....	102
Figure 60: Installing Rx and Reference Cables.....	103
Figure 61: Assembling Lock Washers onto Connectors.....	103
Figure 62: Installing WLAN and GNSS Rubber Plugs.....	103
Figure 63: Installing Power Amplifier Module into Repeater.....	104
Figure 64: Securing Power Amplifier Module to Repeater Chassis.....	104
Figure 65: Securing Modem to Repeater Frame.....	105
Figure 66: Securing Rx and Reference Cable Connectors.....	105
Figure 67: Modem FRU Product Label.....	106
Figure 68: Installing Power Supply Module.....	106
Figure 69: Installing M4 Screws.....	107
Figure 70: Snapping Fan Cable.....	107
Figure 71: Installing Fan.....	108
Figure 72: Installing Front Panel.....	108
Figure 73: Installing Power Screws.....	109
Figure 74: Securing Cables.....	109

Figure 75: Securing Front Housing.....	110
Figure 76: Installing M3 Screws.....	111
Figure 77: SLR 5000 Series Assembly Exploded View.....	111
Figure 78: Floor Mount Cabinet.....	119
Figure 79: Modular Rack.....	120
Figure 80: Desk Mount Installation.....	124
Figure 81: Back Panel Connector Names and Locations.....	124
Figure 82: Location of USB Connector.....	125
Figure 83: CPS Settings to Configure SLR 5000 Series Repeater for Analog Mode.....	137
Figure 84: Model Zetron 38 Repeater Panel.....	138
Figure 85: Signal Connections between SLR 5000 Series Repeater and Community Repeater Panel.....	139
Figure 86: CPS Configuration for Community Repeater Panel (1 of 2).....	140
Figure 87: CPS Configuration for Community Repeater Panel (2 of 2).....	140
Figure 88: Zetron Model 30 Phone Patch.....	142
Figure 89: Signal Connections between SLR 5000 Series Repeater and Zetron Model 30 Phone Patch (Analog Phone Patch Cable & Digital Phone Patch Cable).....	142
Figure 90: CPS Configuration for Phone Patch (1 of 2).....	143
Figure 91: CPS Configuration for Phone Patch (2 of 2).....	144
Figure 92: Model L3276 Tone Remote Adapter.....	145
Figure 93: Signal Connections between SLR 5000 Series Repeater and Motorola L3276 25-Pin connector for a 15 Channel Remote Control.....	146
Figure 94: CPS Configuration for L3276 Tone Remote Adapter (For a 15 Channel Remote Control).....	147
Figure 95: Model Trident's Marauder.....	148
Figure 96: Model Trident's Raider.....	148
Figure 97: Model Trident's NTS.....	149
Figure 98: Signal connections between SLR 5000 Series Repeater, Trident Model Raider, Marauder and NTS.....	150
Figure 99: CPS Configuration for Trident Model Raider, Marauder and NTS.....	151
Figure 100: Reference frame for the point of interest (POI) cylindrical co-ordinates.....	156
Figure 101: Schematic of the ground-level exposure model adopted for the assessment.....	157
Figure 102: Compliance boundary for general public (GP) and occupational (OCC) exposure.....	159

This page intentionally left blank.

List of Tables

Table 1: Callout Legend.....	34
Table 2: Callout Legend.....	34
Table 3: Callout Legend.....	35
Table 4: Callout Legend.....	35
Table 5: SLR 5000 Series Frequency Ranges and Power Levels.....	37
Table 6: SLR 5000 Series Repeater General Specifications (All Bands).....	37
Table 7: SLR 5000 Series Repeater Specifications.....	38
Table 8: Front Panel LED indicators.....	41
Table 9: SLR 5000 Series Front Panel LED Definitions.....	42
Table 10: Callout Legend.....	48
Table 11: Specifications of Receiver Subsystem.....	49
Table 12: Specifications of Transmitter Exciter Subsystem.....	50
Table 13: Callout Legend.....	56
Table 14: Specifications of Power Amplifier.....	56
Table 15: Callout Legend.....	60
Table 16: Callout Legend.....	60
Table 17: Power Supply AC Performance Specifications.....	60
Table 18: Power Supply DC Performance Specifications.....	61
Table 19: Power Supply Battery Charger Performance Specifications.....	61
Table 20: Callout Legend.....	62
Table 21: Callout Legend	62
Table 22: Callout Legend.....	63
Table 23: Power Supply Output Cable Signalling.....	63
Table 24: Callout Legend.....	65
Table 25: Connector Type and Primary Function.....	67
Table 26: AC Power Inlet Connector.....	68
Table 27: Callout Legend.....	68
Table 28: DC Power Inlet/DC Charger Outlet Connector.....	69
Table 29: USB Connector.....	70
Table 30: Ethernet 1 Connector.....	70
Table 31: Ethernet 2 Connector.....	71
Table 32: Auxiliary Connector.....	71
Table 33: Frequency Reference.....	74
Table 34: Recommended Test Equipment.....	77
Table 35: Callout Legend.....	86
Table 36: Callout Legend.....	86

List of Tables

Table 37: SLR 5000 Series Exploded View Parts List.....	112
Table 38: Torque Specifications for Nuts and Screws.....	113
Table 39: Cabinet Models.....	118
Table 40: Cabinet Slide.....	118
Table 41: Rack Models.....	119
Table 42: Connector Type and Primary Function.....	124
Table 43: Callout Legend.....	125
Table 44: EME Compliance Distances Based on Example UHF Evaluation.....	155

Summary of Bands Available

Table below lists the SLR 5000 Series Repeater bands available in this manual. For details, see Model Charts section.

Frequency Band	Bandwidth	Power Level
VHF	136–174 MHz	1–50 W
UHF	400–470 MHz	1–50 W

This page intentionally left blank.

Notice

Commercial Warranty

Limited Warranty

MOTOROLA COMMUNICATION PRODUCTS

I. What This Warranty Covers And For How Long

MOTOROLA SOLUTIONS INC. ("MOTOROLA") warrants the MOTOROLA manufactured Communication Products listed below ("Product") against defects in material and workmanship under normal use and service for a period of time from the date of purchase as scheduled below:

Repeater	Two (2) Years
Product Accessories	One (1) Year

Motorola, at its option, will at no charge either repair the Product (with new or reconditioned parts), replace it (with a new or reconditioned Product), or refund the purchase price of the Product during the warranty period provided it is returned in accordance with the terms of this warranty. Replaced parts or boards are warranted for the balance of the original applicable warranty period. All replaced parts of Product shall become the property of MOTOROLA.

This express limited warranty is extended by MOTOROLA to the original end user purchaser only and is not assignable or transferable to any other party. This is the complete warranty for the Product manufactured by MOTOROLA. MOTOROLA assumes no obligations or liability for additions or modifications to this warranty unless made in writing and signed by an officer of MOTOROLA. Unless made in a separate agreement between MOTOROLA and the original end user purchaser, MOTOROLA does not warrant the installation, maintenance or service of the Product.

MOTOROLA cannot be responsible in any way for any ancillary equipment not furnished by MOTOROLA which is attached to or used in connection with the Product, or for operation of the Product with any ancillary equipment, and all such equipment is expressly excluded from this warranty. Because each system which may use the Product is unique, MOTOROLA disclaims liability for range, coverage, or operation of the system as a whole under this warranty.

II. General Provisions

This warranty sets forth the full extent of MOTOROLA's responsibilities regarding the Product. Repair, replacement or refund of the purchase price, at MOTOROLA's option, is the exclusive remedy. THIS WARRANTY IS GIVEN IN LIEU OF ALL OTHER EXPRESS WARRANTIES. IMPLIED WARRANTIES, INCLUDING WITHOUT LIMITATION, IMPLIED WARRANTIES OF MERCHANTABILITY AND FITNESS FOR A PARTICULAR PURPOSE, ARE LIMITED TO THE DURATION OF THIS LIMITED WARRANTY. IN NO EVENT SHALL MOTOROLA BE LIABLE FOR DAMAGES IN EXCESS OF THE PURCHASE PRICE OF THE PRODUCT, FOR ANY LOSS OF USE, LOSS OF TIME, INCONVENIENCE, COMMERCIAL LOSS, LOST PROFITS OR SAVINGS OR OTHER INCIDENTAL, SPECIAL OR CONSEQUENTIAL DAMAGES ARISING OUT OF THE USE OR INABILITY TO USE SUCH PRODUCT, TO THE FULL EXTENT SUCH MAY BE DISCLAIMED BY LAW.

III. State Law Rights

SOME STATES DO NOT ALLOW THE EXCLUSION OR LIMITATION OF INCIDENTAL OR CONSEQUENTIAL DAMAGES OR LIMITATION ON HOW LONG AN IMPLIED WARRANTY LASTS, SO THE ABOVE LIMITATION OR EXCLUSIONS MAY NOT APPLY.

This warranty gives specific legal rights, and there may be other rights which may vary from state to state

IV. How To Get Warranty Service

You must provide proof of purchase (bearing the date of purchase and Product item serial number) in order to receive warranty service and, also, deliver or send the Product item, transportation and insurance prepaid, to an authorized warranty service location. Warranty service will be provided by Motorola through one of its authorized warranty service locations. If you first contact the company which sold you the Product, it can facilitate your obtaining warranty service. You can also .

V. What This Warranty Does Not Cover

Defects or damage resulting from use of the Product in other than its normal and customary manner.

Defects or damage from misuse, accident, water, or neglect.

Defects or damage from improper testing, operation, maintenance, installation, alteration, modification, or adjustment.

Breakage or damage to antennas unless caused directly by defects in material workmanship.

A Product subjected to unauthorized Product modifications, disassemblies or repairs (including, without limitation, the addition to the Product of non-Motorola supplied equipment) which adversely affect performance of the Product or interfere with Motorola's normal warranty inspection and testing of the Product to verify any warranty claim.

Product which has had the serial number removed or made illegible.

Freight costs to the repair depot.

A Product which, due to illegal or unauthorized alteration of the software/firmware in the Product, does not function in accordance with MOTOROLA's published specifications or the FCC type acceptance labeling in effect for the Product at the time the Product was initially distributed from MOTOROLA.

Scratches or other cosmetic damage to Product surfaces that does not affect the operation of the Product.

Normal and customary wear and tear.

VI. Patent And Software Provisions

MOTOROLA will defend, at its own expense, any suit brought against the end user purchaser to the extent that it is based on a claim that the Product or parts infringe a United States patent, and MOTOROLA will pay those costs and damages finally awarded against the end user purchaser in any such suit which are attributable to any such claim, but such defense and payments are conditioned on the following:

that MOTOROLA will be notified promptly in writing by such purchaser of any notice of such claim;

that MOTOROLA will have sole control of the defense of such suit and all negotiations for its settlement or compromise; and

should the Product or parts become, or in MOTOROLA's opinion be likely to become, the subject of a claim of infringement of a United States patent, that such purchaser will permit MOTOROLA, at its option and expense, either to procure for such purchaser the right to continue using the Product or parts or to replace or modify the same so that it becomes noninfringing or to grant such purchaser a credit for the Product or parts as depreciated and accept its return. The depreciation will be an equal amount per year over the lifetime of the Product or parts as established by MOTOROLA.

MOTOROLA will have no liability with respect to any claim of patent infringement which is based upon the combination of the Product or parts furnished hereunder with software, apparatus or devices not furnished by MOTOROLA, nor will MOTOROLA have any liability for the use of ancillary equipment or software not furnished by MOTOROLA which is attached to or used in connection with the Product. The foregoing states the entire liability of MOTOROLA with respect to infringement of patents by the Product or any parts thereof.

Laws in the United States and other countries preserve for MOTOROLA certain exclusive rights for copyrighted MOTOROLA software such as the exclusive rights to reproduce in copies and distribute

copies of such Motorola software. MOTOROLA software may be used in only the Product in which the software was originally embodied and such software in such Product may not be replaced, copied, distributed, modified in any way, or used to produce any derivative thereof. No other use including, without limitation, alteration, modification, reproduction, distribution, or reverse engineering of such MOTOROLA software or exercise of rights in such MOTOROLA software is permitted. No license is granted by implication, estoppel or otherwise under MOTOROLA patent rights or copyrights.

VII. Governing Law

This Warranty is governed by the laws of the State of Illinois, USA.

This page intentionally left blank.

Chapter 1

SLR 5000 Series Repeater

1.1

Notations Used in This Manual

Throughout the text in this publication, you will notice the use of WARNING, CAUTION and Note notations. These notations are used to emphasize that safety hazards exist, and due care must be taken and observed.



NOTICE: An operational procedure, practice, or condition which is essential to emphasize.



CAUTION: CAUTION indicates a potentially hazardous situation which, if not avoided, might result in equipment damage.



WARNING: WARNING indicates a potentially hazardous situation which, if not avoided, could result in death or injury.



Symbol indicates areas of the product that pose potential burn hazards.

1.2

Description

The Motorola SLR 5000 Series Repeater provides a modular, flexible analog and digital station designed for today's communication systems and for the future. The station is available for use in these configurations:

- Analog Conventional
- Digital (MOTOTRBO)
 - MOTOTRBO DMR Tier 2 Conventional – Single Site
 - MOTOTRBO DMR Tier 2 Conventional – IP Site Connect
 - MOTOTRBO Capacity Plus Trunking
 - MOTOTRBO Connect Plus Trunking
 - MOTOTRBO Digital Voting
- LTR Trunking
- Passport Trunking
- MPT1327 Trunking



NOTICE: Certain software features enabled via the CPS can be configured with the Online Help or with a regional representative. Refer to the regional Ordering Guide to determine the features available within the respective regions.

The SLR 5000 series can either be configured as a stand-alone repeater or as a repeater connected to a back-end network, as in the case of operating in IP Site Connect mode. As a repeater, it listens on one uplink frequency, and then re-transmits on a downlink frequency, thus providing the RF interface to the field subscribers. When configured for analog station operation, the repeater is designed to operate with most existing analog systems, which enables a smooth migration to the MOTOTRBO system.

When configured for digital operation, the repeater offers additional services. The digital repeater operates in TDMA mode, which essentially divides one channel into two virtual channels using time

slots; therefore the user capacity is doubled. The repeater utilizes embedded signaling to inform the field radios of the busy/idle status of each channel (time slot), the type of traffic, and even the source and destination information.

The SLR 5000 series facilitates the field replaceable unit (FRU) concept of field repair to maximize system uptime. The FRU concept also aids in allowing the end user/ maintainer to lower their inventory costs. The base model SLR 5000 series FRUs are as follows:

- Modem FRU
- Power Amplifier FRU
- Power Supply FRU
- Front Panel FRU

See [Figure 1: Front view of the SLR 5000 Series Repeater on page 34](#) for the front view and [Figure 2: Rear view of the SLR 5000 Series Repeater on page 34](#) for the rear view of SLR 5000 series repeater. [Figure 3: Front view \(without top cover\) of the SLR 5000 Series Repeater on page 35](#) shows the front view portion of the repeater without the top cover and [Figure 4: Front view \(without top and bottom covers and front panel\) of the SLR 5000 Series Repeater on page 35](#) shows the front view portion of the repeater without the top cover, bottom cover, and front panel.

Figure 1: Front view of the SLR 5000 Series Repeater

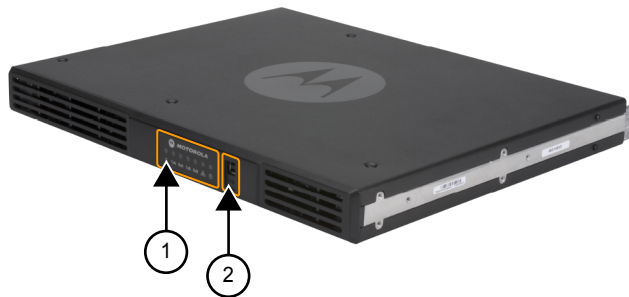

Table 1: Callout Legend

Label	Description
1	Front Panel LED Indicators
2	USB Port

Figure 2: Rear view of the SLR 5000 Series Repeater

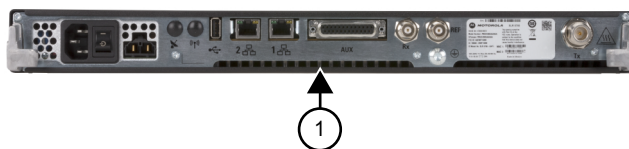

Table 2: Callout Legend

Label	Description
1	Back Panel Interface Connectors and Power Switch

Figure 3: Front view (without top cover) of the SLR 5000 Series Repeater

Table 3: Callout Legend

Label	Description
1	Power Amplifier Module
2	Modem Module
3	Power Supply Module

Figure 4: Front view (without top and bottom covers and front panel) of the SLR 5000 Series Repeater

Table 4: Callout Legend

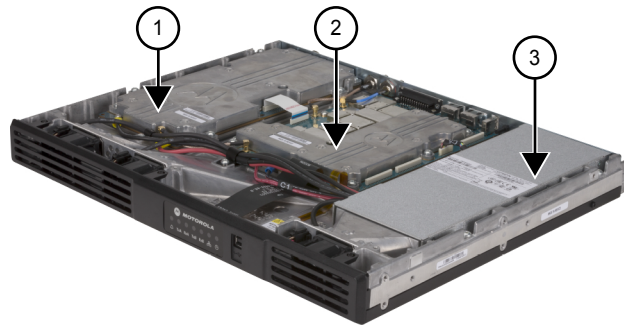
Label	Description
1	Front Panel Board

1.3

Operating Features

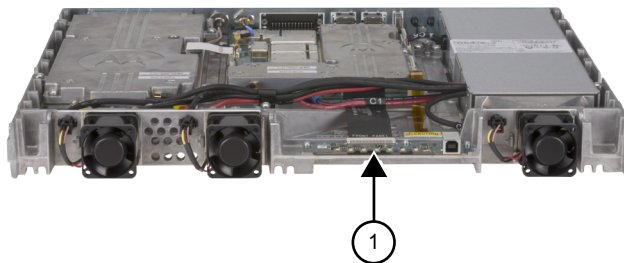
The following are the standard features of an SLR 5000 series model:

- MOTOTRBO Conventional Operation (2-Slot TDMA, 4FSK Modulation)
- Analog Conventional Operation (FM)
- Continuous Duty Cycle Operation over -30 °C to +60 °C
- Meets or exceeds the following standards:
 - TIA603D
 - ETSI EN 300 086
 - ETSI EN 300 113
 - ETSI TS 102 361-1 Part 1: DMR Air Interface Protocol

Motorola Solutions Confidential

- ETSI TS 102 361-2 Part 2: DMR Voice and Generic Services and Facilities
- ETSI TS 102 361-3 Part 3: DMR Packet Data Protocol
- ETSI TS 102 361-4 Part 4: DMR Trunking Protocol
- California Energy Commission (CEC) - Compliant to Title 20 Appliance Efficiency Regulations when operated in Battery Charger Only mode with Sprinter Battery S12V370. Charge time may take up to 40 hr.
- AMBE +2™ Digital VOCODER
- Synthesized Frequency Generation
- Female N-type Antenna Connector (Tx)
- Female BNC Antenna Connector (Rx)
- Ethernet Port (Network)
- Front-mounted USB Port (Service)
- 12 configurable GPIO ports (Digital)
- 4 configurable GPI ports (Analog)
- 2 configurable GPO ports (Analog)
- Power for third-party controllers (1 A)
- 1.5 PPM Frequency Stability (Temperature and 1-Year Aging) (VHF and UHF)
- External Reference Capability
- Switching Power Supply operates from 85–264 VAC (47–63 Hz)
- Multi-Power Source configurable (AC, DC, or AC with Battery Revert)
- Integrated 3 A battery charger
- Station Diagnostic Tests – Fixed Set of Tests run upon Start-up
- Physical Dimensions: 1.75 in. H x 19 in. W x 14.6 in. D (44 x 483 x 370 mm) 1RU
- Weight: 19 lb (8.62 kg) excluding cabinet or other peripheral equipment

Motorola Solutions Network Interface:

- IP Site Connect
- Repeater Diagnostics and Control (RDAC)
- Capacity Plus
- Connect Plus

Third-Party Controller Interface:

- Phone Patch
- Multi-Coded Squelch Interface (Repeater Panel)
- Tone Remote Adapter
- LTR Trunking
- Passport Trunking
- MPT1327 Trunking



NOTICE: The SLR 5000 series repeater only supports the third-party controllers noted above when it is configured in analog mode. The exception is phone patch in digital mode.

In addition, the following features are also included. These features are shipped in a preset condition, but may be altered through the use of the CPS.

- 64 Tx/Rx Frequencies – Factory Programmed with 1 Tx, 1 Rx
- 12.5 kHz or 25 kHz Operation – Factory Programmed to 12.5 kHz
- 1 Tx and 1 Rx (PL or DPL) Squelch Code per channel – Factory Programmed to CSQ
- Base Station Identification (BSI) – Factory Programmed as "BLANK" ("BLANK" disables BSI)
- Push-To-Talk (PTT) Priority – Factory Programmed to Repeat Path

1.4

Frequency Ranges and Power Levels

The SLR 5000 series repeater is available in the following frequency ranges and power levels table.

Table 5: SLR 5000 Series Frequency Ranges and Power Levels

Frequency Band	Bandwidth	Power Level
VHF	136–174 MHz	1–50 W
UHF	400–470 MHz	1–50 W

1.5

Specifications

Specifications of the SLR 5000 series repeater are available in the following tables.

Table 6: SLR 5000 Series Repeater General Specifications (All Bands)

Parameter	Specifications
Number of Channels	64
Frequency Generation	Synthesized
Input Voltage AC	100–240 VAC (47–63 Hz)
Input Voltage DC	11.0–14.4 VDC
Power Supply Type	Switching
Station Weight	19 lbs (8.62 kg)
Temperature Range	-30 °C to +60 °C (-22 °F to +140 °F)
Humidity Range	RH of 95%, non-condensing at 50 °C (122 °F)
Antenna Connectors	Tx: N-Type, Rx: BNC
Modes of Operation	Half-Duplex/Duplex
Rack Unit	1
Height	1.75 in. (44 mm)
Width	19 in. (483 mm)
Depth	14.6 in. (370 mm)

Table 7: SLR 5000 Series Repeater Specifications

Parameter	Specifications	
	VHF	UHF
Input Power (All Modulations)		
Standby (AC Line 117 V/220 V)	0.18 A/0.25 A	
50 W Transmit at Rated Power (AC Line 117 V/220 V)	1.5 A/0.9 A	
Standby (13.6 VDC)	0.73 A	
50 W Transmit at Rated Power (13.6 VDC)	9.5 A	
Frequency Reference		
Internal Frequency Stability (PPM)	±0.5 PPM (temperature)	
External Reference Capable	Yes	
Frequency Bands		
Electronic Bandwidth	136–174 MHz	400–470 MHz
Receiver		
Selectivity 25 kHz/12.5 kHz (TIA603D)	83 dB/55 dB	80 dB/55 dB
Selectivity 25 kHz/12.5 kHz (TIA603)	83 dB/68 dB	80 dB/55 dB
Selectivity 25 kHz/12.5 kHz (ETSI)	70 dB/63 dB	
Sensitivity (12 dB SINAD)	0.22 uV	
Sensitivity (5% BER)	0.22 uV	
Intermodulation Rejection (TIA603D)	82 dB	
Intermodulation Rejection (ETSI)	73 dB	
Spurious Rejection (TIA603D)	95 dB	
Spurious Rejection (ETSI)	90 dB	
Conducted Spurious Emissions	-57 dBm	
Audio Distortion	<1%	
Audio Response	Per TIA/ETSI	
FM Hum and Noise 25 kHz/12.5 kHz	-50 dB/-45 dB	
Transmitter		
Rated Output Power (Continuous Duty)	1–50 W	
Intermodulation Attenuation	40 dB	
Adjacent Channel Power 25 kHz/12.5 kHz	78 dB/62 dB	
Modulation Fidelity (4FSK)	FSK Error 5%, FSK Magnitude 1%	
Wideband Noise (1 MHz) @ Rated Pout	-152 dBc/Hz	
Rated System Deviation	±2.5 kHz @ 12.5 kHz, ±5.0 kHz @ 25 kHz	

Table continued...

¹ Typical performance under the following conditions (when applicable): Battery charging disabled and nominal VSWR conditions (VSWR <1.5:1)

Parameter	Specifications	
	VHF	UHF
Spurious Harmonics and Emissions	-36 dBm < 1 GHz, -30 dBm > 1 GHz	
Audio Distortion	< 1%	
Audio Response	Per TIA/ETSI	
FM Hum and Noise 25 kHz/12.5 kHz	-50 dB/-45 dB	
FCC Identifier	ABZ99FT3094	ABZ99FT4096
FCC Emission Designators	11K0F3E, 16K0F3E, 7K60FXD, 7K60F7D, 7K60FXE, 7K60F7E, and 7K60F7W	
Industry Canada	109AB-99FT3094	109AB-99FT4096
• IC certification/registration number	SLR 5000-VHF	SLR 5000-UHF
• IC model number	Tx: 138–174 MHz	Tx: 406.1–430 MHz and 450–470 MHz
• Tx/Rx Frequency range	Rx: 138–174 MHz	Rx: 406.1–430 MHz and 450–470 MHz

All specifications noted above are in accordance to their respective TIA603D, ETSI EN 300 086, and ETSI EN 300 113 standards unless otherwise noted.

1.6

Theory of Operation

The SLR 5000 series repeater provides the radio frequency (RF) link between the repeater and the subscriber radios.

The repeater acquires inbound signals via its external receive (Rx) antenna and then amplifies, filters and demodulates the signals into data or voice packets. From that point, the data is either forwarded to the repeater's transmitter to subscriber radios, and/or the data is delivered via a wired interface for distribution to networked repeaters, consoles, or other networked infrastructure.

The SLR 5000 series repeater consists of a Modem, Power Amplifier (PA), Front Panel and Power Supply (PS). These modules are also known as field replaceable units (FRU).

- The Modem module is comprised of three subsystems, which are the Receiver subsystem, Exciter subsystem, and Station Control subsystem. At a high level, these subsystems are further explained as follows:
 - The Receiver subsystem is a dual heterodyne Receiver which receives the RF signal from the subscriber's transmitter. It then converts the resulting final intermediate frequency (IF) from an analog signal to that of a digital word in IQ signal format. Finally, the Receiver delivers the IQ signal, via the SSI bus, to the Station Control subsystem for demodulation. Additionally, the Receiver subsystem also provides for its own metering and diagnostics via software, as well as self-contained calibration (no field tuning is needed for the Receiver subsystem).
 - The Exciter subsystem converts a two-port base band data signal, sent over the SSI bus from the Station Control subsystem, to an analog signal representation. The analog signal is then modulated with a low power RF transmitter carrier that is generated by the Exciter subsystem. The power modulated RF carrier is then amplified and delivered to the PA at an intermediate level of approximately +36 dBm for further amplification. The Exciter subsystem and PA constitute the transmitter of the SLR 5000 series repeater. Additionally, the Exciter subsystem also provides its own metering and diagnostics via software, as well as a self-contained calibration (no field tuning is needed for the Exciter subsystem).

- The heart of the Station Control subsystem is the Texas Instruments DM8148 Host/ DSP processor. In general, the SCM controls the entire coordination of the repeater functions. Specifically, the Station Control subsystem provides for the following functionalities:
 - + Contains and runs the preloaded repeater software
 - + Manages inbound and outbound RF and Audio traffic
 - + Provides an on-board USB port for local configuring, alignment and diagnostics via the following applications:
 - Customer Programming Software (CPS)
 - Tuner application
 - Repeater Diagnostic and Control (RDAC) software
 - + Provides an Ethernet port for IP site connectivity and remote RDAC
 - + Provides GPIO connectivity for third party controller interfaces
 - + Provides for analog repeater audio connectivity
 - + Data and Control to the Receiver subsystem via the SPI and SSI respectively
 - + Data and Control to the Exciter subsystem via the SPI and SSI respectively
 - + Control of the PA's set power via the SPI
 - + Configuration and fault management of all subsystems including the PS and PA
 - + Generates the internal station reference
 - + Provides control of the front panel module's indicator LEDs.
- The PA module amplifies the intermediate level modulated RF signal from the Modem. It then delivers the amplified signal to the transmitter antenna port at a power level within the rated power band of the repeater, for transmission to the subscriber radios. In addition to its primary task of amplification, the PA provides the following hardware functions for the repeater.
 - + Harmonic attenuation
 - + Inter-modulation attenuation (IMA) suppression
 - + VSWR detection
 - + RF power control (primary means)
 - + Meters for diagnostics
 - + Power rollback for temperature, VSWR, and voltage
 - + Self-Contained calibration (no field alignment is needed for PA)
- The Front Panel module provides LED indications for general assessment of the status and operational condition of the repeater. Additionally, the front panel also provides a USB service port for configuration and alignment of the repeater.
- The PS Module provides DC power to the Modem, PA and Front Panel. It can also be used to provide auxiliary power (nominal 13.6 VDC) to a number of third party controllers. Additionally, it can operate in three different input modes:
 - + AC Input Only
 - + DC Input Only
 - + AC with Battery Revert

In addition to providing power to the noted FRU and controllers, the PS also provides the following:

- AC Failure detect signaling to the Modem
- Output over-current protection

- Integrated 2 stage 3 amp battery charger

Further details can be found in the individual sections of the respective FRU chapters of this manual.

1.7

Basic Repeater Level Troubleshooting – RDAC and LEDs

Diagnostic tests are available for the Modem, PA, and Power Supply Modules. If a problem occurs during station operation, it is logged as an alarm that is read with the Repeater Diagnostic and Control application (RDAC).

Figure 5: RDAC Diagnostic Screen

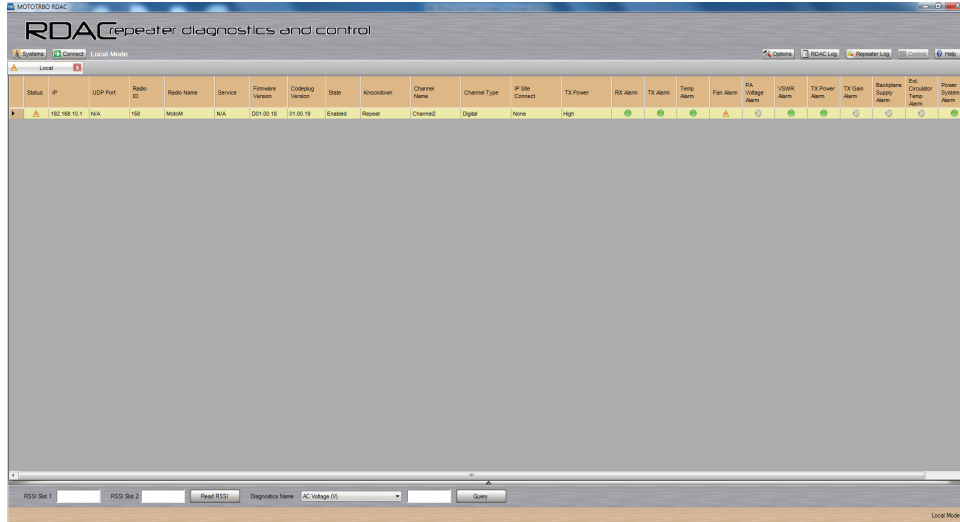

The station operator will then evaluate the problem locally or remotely, as the station maintains an Alarm Log with the name of the alarm that has failed since the last power up. Via the RDAC application's Alarm Log, the alarm messages will aid in identifying the FRU that failed along with the fault condition.

After booting up the repeater, the 7 LEDs (Power/Status, Tx Slot 1, Tx Slot 2, Rx Slot 1, Rx Slot 2, Network, and Reference LEDs) will flash in unison.

The general status and condition of the SLR 5000 series repeater can be obtained by observing the seven LED indicators on the front panel. [Table 8: Front Panel LED indicators on page 41](#) shows the LED symbols and their meaning, while [Table 9: SLR 5000 Series Front Panel LED Definitions on page 42](#) identifies the information conveyed via the LED indicators.

Table 8: Front Panel LED indicators

LED	Definition
	Status
Tx A	Tx Slot 1
Rx A	Rx Slot 1
Tx B	Tx Slot 2
Rx B	Rx Slot 2

Table continued...



LED	Definition
	Ethernet Link/Network Connectivity
	Reference

Table 9: SLR 5000 Series Front Panel LED Definitions

LED Function Name	LED Color	LED State	Status Indication
Power/Status	Off	Off	Off
	Green	Flashing	Operating Normally, with DC power
		Solid	Operating Normally, with AC power
	Red	Flashing	Repeater is Disabled (by customer)
		Solid	Not Operational – Major Alarm
	Amber	Flashing ²	Check Alarm Log – Alarm occurred and cleared but remains latched (configurable)
Solid		Repeater Operational – Minor Alarm	
Tx A	Off	Off	Transmitter is not transmitting
	Green	Solid	Tx slot A or Analog (at desired power)
	Amber ²	Solid	Tx slot A or Analog (at less than desired power)
	Red ²	Solid	Tx Fail
		Flashing	Tx Inhibit
Rx A	Off	Off	No receive carrier detected
	Green	Solid	Rx Slot A or Analog (qualifier met)
	Amber ²	Solid	Rx Slot A or Analog (non-qualified)
Tx B	Off	Off	Transmitter is not transmitting
	Green	Solid	Tx slot B or Analog (at desired power)
	Amber ²	Solid	Tx slot B or Analog (at less than desired power)
	Red ²	Solid	Tx Fail
		Flashing	Tx Inhibit
Rx B	Off	Off	No receive carrier detected
	Green	Solid	Rx Slot B or Analog (qualifier met)
	Amber ²	Solid	Rx Slot B or Analog (non-qualified)
Ethernet/Network Connectivity	Off	Off	No Ethernet connection
	Green	Solid	Connectivity/Linked
		Flashing	Attempting to connect to the system

Table continued...

² Not supported in initial release.

LED Function Name	LED Color	LED State	Status Indication
Reference	Off	Off	No External Reference is present
	Green	Solid	Locked to External Reference (1 pps ² , 5 MHz, 10 MHz)



NOTICE:

All LEDs flashing in unison indicate the repeater is booting up.

The RDAC application will be needed when the Status LED is red (solid or flashing). This status indicates a minor or major alarm. The RDAC application is used to identify the specific alarm and probable diagnosis to aid in identifying the FRU at fault.

1.8

Repeater Model Numbering Scheme

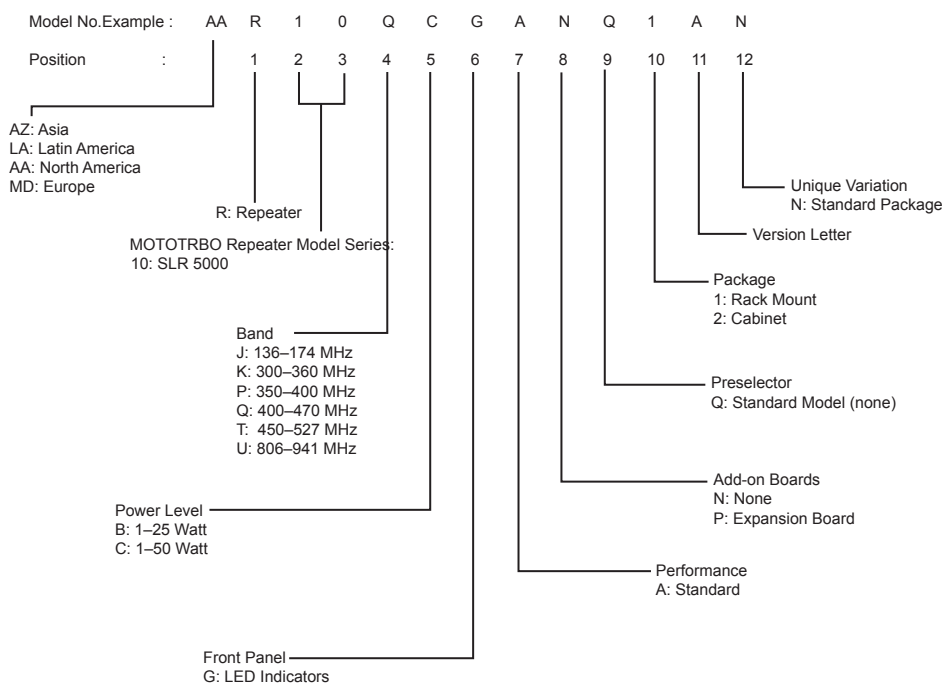

Figure 6: Repeater Model Numbering Scheme

1.9

Model Chart

1.9.1

VHF High Power

SLR 5700, VHF, 136–174 MHz	
Model/Item	Description
AAR10JCGANQ1AN	136–174 MHz, 1–50 W SLR 5700 Repeater
X PMTD4013_S	Modem Structure Kit/FRU

Table continued...

SLR 5700, VHF, 136–174 MHz	
Model/Item	Description
X PMTD4012_S	Power Amplifier Structure Kit/FRU
X PMPN4026_S	Power Supply Structure Kit/FRU
X PMLN6490_S	Front Panel Board Structure Kit/FRU
X 3087791G01	Power Cable, US
X MN001443A01	Quick Start Guide
x = Indicates compatibility with model(s)	

1.9.2

UHF1 High Power

SLR 5700, UHF, 400–470 MHz	
Model/Item	Description
AAR10QCGANQ1AN	400–470 MHz, 1–50 W SLR 5700 Repeater
X PMTE4022_S	Modem Structure Kit/FRU
X PMTE4023_S	Power Amplifier Structure Kit/FRU
X PMPN4026_S	Power Supply Structure Kit/FRU
X PMLN6490_S	Front Panel Board Structure Kit/FRU
X 3087791G01	Power Cable, US
X MN001443A01	Quick Start Guide
x = Indicates compatibility with model(s)	

Chapter 2

SLR 5000 Series Satellite Receiver

2.1

Description

The main purpose of the Satellite Receiver is to eliminate “dead zones” in a communications system by improving the “talk-in” coverage on a particular receive frequency when used in a receiver voting system.

The Motorola SLR 5000 series repeater is not offered as an exclusive Satellite Receiver only model, rather the SLR 5000 series can be configured via the CPS to operate as a Satellite Receiver in a receive only mode of operation. As such, the context of this chapter will assume that the SLR 5000 series repeater is configured as a Satellite Receiver.



NOTICE: Configuring the SLR 5000 Series as a Satellite Receiver is only compatible with the MOTOTRBO Digital Voting feature.

2.2

Operating Features

The features are identical to the SLR 5000 series repeater, with the exception that all transmitter related functions are not applicable. See [Operating Features on page 35](#) for more details.

2.3

Frequency Ranges

The supported frequency ranges are identical to the SLR 5000 series repeater's receive frequency ranges. See [Frequency Ranges and Power Levels on page 37](#) for more details.

2.4

Specifications

The specifications are identical to the SLR 5000 series repeater, with the exception that all transmitter related specifications are not applicable. See [Specifications on page 37](#) for more details.

2.5

Configuration

Other than setting the general personality configurations, one must additionally set the “Operation Mode” parameter under the “General Settings” menu in the CPS to that of “Digital Satellite Receiver.” See [Figure 7: “Operation Mode” configuration for Satellite Receiver Functionality on page 46](#) for the screenshot of the “Operation Mode” parameter.

Figure 7: “Operation Mode” configuration for Satellite Receiver Functionality

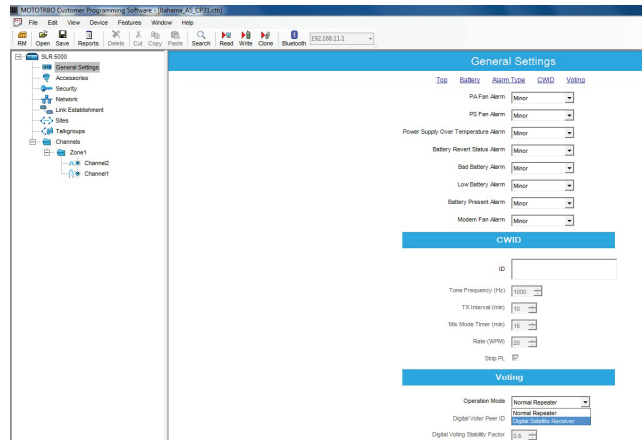

2.6

Basic Station Level Troubleshooting – RDAC and LEDs

The troubleshooting procedures are similar to the SLR 5000 series repeater with regards to the control, power supply, and receiver sub-systems. See [Basic Repeater Level Troubleshooting – RDAC and LEDs on page 41](#) for more details.



NOTICE: When configured for receiver only operation, the SLR 5000 series repeater does not support any transmitter sub-system functions. As such, disregard all references to the transmitter section in [Basic Repeater Level Troubleshooting – RDAC and LEDs on page 41](#). This includes any transmitter related topics in the RDAC and the front panel LEDs.

2.7

Model Chart

The model chart is identical to the SLR 5000 series repeater. See [Model Chart on page 43](#) for more details.

Chapter 3

SLR 5000 Series Modem

3.1

Description

The Modem Module is described in this section. A general description, identification of inputs and outputs, and functional theory of operation are provided. The information provided is sufficient to give service personnel a functional understanding of the module, allowing maintenance and troubleshooting to the module level.

3.1.1

General Description

The Modem Module consists of a single printed circuit board in a clamshell housing assembly. It provides the receiver, exciter and station control functionality for the repeater. Additionally the external connections to the station are connected directly to the modem module.



NOTICE: The modem cooling fan is replaceable and external to the modem itself. See [SLR 5000 Series Maintenance and Disassembly/Reassembly on page 93](#) for replacement details.

3.1.2

Input and Output Connections

The following figure shows the Modem Module input and output external connections.

Figure 8: Modem Module Connector Locations

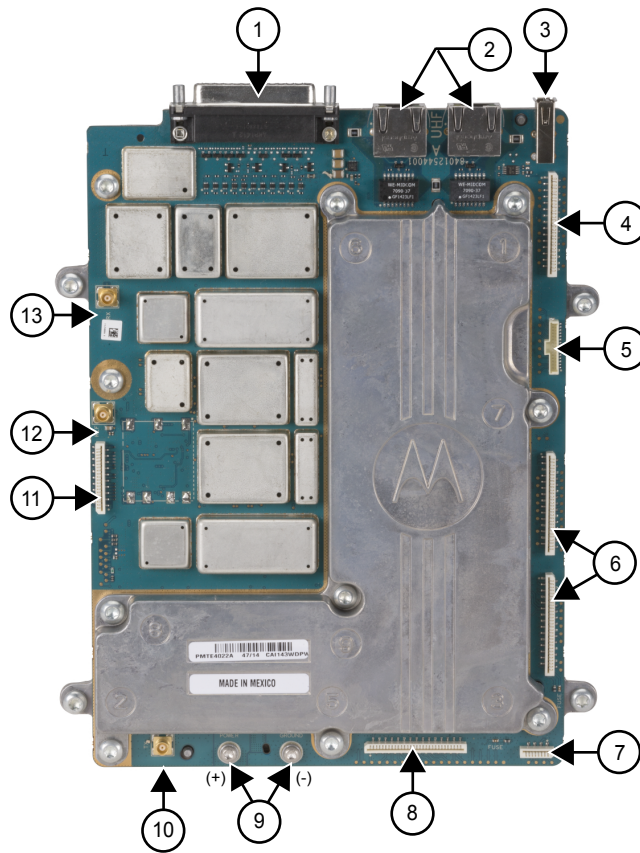

Table 10: Callout Legend

Label	Description
1	Auxiliary Connector
2	Ethernet Connectors
3	USB Host
4	Future Expansion Port
5	PSU Digital Interface
6	Future Expansion Ports
7	Chassis ID Connector
8	Front Panel Interface
9	DC Power Input
10	Tx Exciter Output
11	PA Digital Interface
12	External Reference Input
13	Receiver Input

3.1.3

Frequency Bands

The Modem Module covers the following bands with unique models:

- VHF
- UHF

3.2

Receiver Subsystem

3.2.1

Description

The Modem Module includes the receiver circuitry for the station. A cable connects the board connector to a BNC connector located on the rear panel of the repeater. See [Figure 8: Modem Module Connector Locations on page 48](#) for the location of this connector. The receiver section performs highly-selective bandpass filtering and dual down-conversion of the desired RF signal. A custom Receiver IC then performs an analog-to-digital conversion of the desired received signal and outputs the digitized signal to the controller section via a serial synchronous interface. Included in the receiver section is:

- Frequency Synthesizer Circuitry – Consists of a phase-locked loop and Voltage-Controlled Oscillator (VCO), generates the first LO injection signal.
- Varactor-tuned Preselector Filter(s) – Provides bandpass filtering of the station Receiver RF input.
- Receiver Front End Circuitry – Performs filtering, amplification, and the first down conversion of the Receiver RF signal.
- Receiver-specific piece of transceiver IC Circuitry – Consists of receiver-specific parts of a transceiver IC which performs the second down conversion, filtering, amplification, and analog-to-digital conversion of the receive signal.
- Analog to Digital Converter (ADC) Circuitry – Converts analog Receiver status signals to digital format for transfer to the controller circuitry located on the Modem Module.

3.2.2

Specifications

Table 11: Specifications of Receiver Subsystem

Parameter	Specifications	
	VHF	UHF
Frequency Bands	136–174 MHz	400–470 MHz
Selectivity 25 kHz/12.5 kHz (TIA603D)	83 dB/55 dB	80 dB/55 dB
Selectivity 25 kHz/12.5 kHz (TIA603)	83 dB/68 dB	80 dB/68 dB
Selectivity 25 kHz/12.5 kHz (ETSI)	70 dB/63 dB	
Sensitivity (12 dB SINAD)	0.22 uV	
Sensitivity (5% BER)	0.22 uV	
Intermodulation Rejection (TIA603D)	82 dB	
Intermodulation Rejection (ETSI)	73 dB	

Table continued...

Parameter	Specifications	
	VHF	UHF
Spurious Rejection (TIA603D)	95 dB	
Spurious Rejection (ETSI)	90 dB	
Audio Distortion	<1%	
FM Hum and Noise 25 kHz/12.5 kHz	-50 dB/-45 dB	

3.3

Transmitter Exciter Subsystem

3.3.1

Description

The Exciter Subsystem in the Modem Module (in conjunction with the Power Amplifier Module) provides the transmitter functions for the station. The Exciter circuitry generates a low-level modulated Radio Frequency (RF) signal which is input to the Power Amplifier (PA) module for further amplification and output to the transmit antenna. A coaxial cable is used to connect the Tx exciter output to the PA module. See [Figure 8: Modem Module Connector Locations on page 48](#) for the exact location of this connector. The Exciter Module interfaces directly with the controller section, which provides control signals and monitoring, and routes transmit data to the Exciter.

The RF carrier is generated by a frequency synthesizer consisting of synthesizer circuitry and Voltage-Controlled Oscillator (VCO) circuitry. Exciter circuit control signals, monitoring, and audio processing are handled by the controller section of the Modem Module. The power leveling circuitry of the transmitter system is located in the Power Amplifier Module and passed onto the exciter stages through the PA-Modem interface flex cable. See [Figure 8: Modem Module Connector Locations on page 48](#) for the location. Included in the exciter section are:

- Frequency Synthesizer Circuitry – Consists of a phase-locked loop and Voltage-Controlled Oscillator (VCO), generates a modulated RF signal at the transmitter carrier frequency.
- RF Isolation Switch – Allows the controller section to turn on/off the Exciter RF input signal which greatly reduces the signal supplied to the Power Amplifier module.
- Analog to Digital Converter (ADC) Circuitry – Converts the analog Exciter status signals to the digital format for transfer, upon request, to the controller section of the Modem Module.
- Low Level Amplifiers – Amplify and buffer the modulated RF signal from the VCO for delivery to the Power Amplifier Module.

3.3.2

Specifications

Table 12: Specifications of Transmitter Exciter Subsystem

Parameter	Specifications	
	VHF	UHF
Frequency Range	136–174 MHz	400–470 MHz
Electronic Bandwidth	Full Bandwidth	
Output Power	6 W	6.2 W
Harmonics	-20 dBc	

3.4

Station Control Subsystem

3.4.1

Description

The Station Control Subsystem is described in this section. A general description, identification of controls, indicators, and inputs/outputs, a functional block diagram, and functional theory of operation are provided.

The Controller circuitry performs the digital signal processing, data formatting and audio routing for the station and provides the external interfaces to the rest of the site.

The Controller section consists of 7 main ICs. These are:

- Texas Instrument DM8148 Host/DSP Processor
- EMMC Flash memory
- DDR3 memory
- Texas Instruments Power Management IC
- NOR Flash
- 2-TI AIC3204 Codecs

General controller functionality includes:

- Data and Control interface to the transceiver ICs
- Audio interface with CODEC ICs
- UART interface to expansion board
- Intermodule communication (SPI, I2C)
- Two Ethernet ports
- USB Device port
- USB Host port
- External physical interfaces (connectors, LEDs, external references etc.)
- Station Reference Control

3.4.2

High Stability Reference Block

The high-stability reference block can be used to enhance the 0.5 ppm Voltage Controlled Temperature Compensated Crystal Oscillator. The block diagram is shown below in [Figure 9: High Stability Reference Circuit on page 51](#). An external reference can be applied to lock the on board VCTCXO. This function can be enabled via the customer programming software. The connection is made via a cable connecting a BNC connector on the rear panel to a connector on the modem module. The location of the connector on the modem module can be found in [Figure 8: Modem Module Connector Locations on page 48](#).

Figure 9: High Stability Reference Circuit

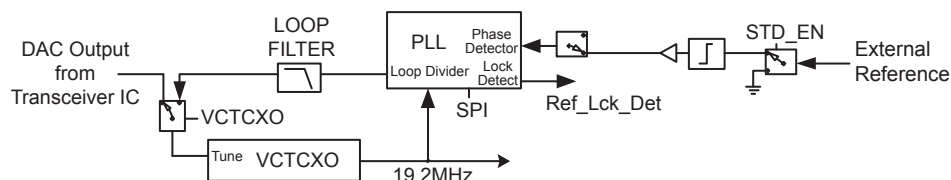

Motorola Solutions Confidential

3.4.3

Audio

The analog audio stages are used exclusively for external accessories connected through the rear DB25 accessory connector.

The critical components of the audio circuit are the TI DM8148 processor and a pair of Texas Instruments AIC3204 dual channel audio codecs. [Figure 10: Audio Block Diagram on page 52](#) details the specific interconnects between the critical components.

Figure 10: Audio Block Diagram

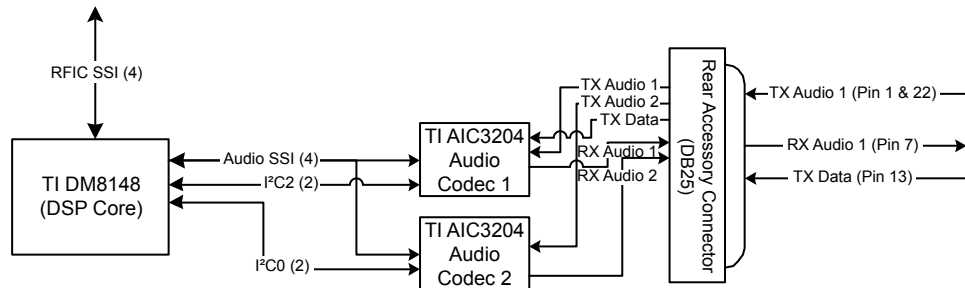

The repeater digital audio is handled primarily by the DM8148 processor. The TX RFIC generates a 24.576 MHz master clock (MCLK) that the DM8148 uses to drive its McASP SSI interface for the audio codecs. The bulk of the audio processing is done in the DaVinci's DSP core. The audio codecs contain DACs and ADCs and handle the conversion of the digital audio to analog audio and vice versa.

There are 2 TX audio lines routed in from the rear accessory connector. These are TX Audio 1 (Pins 1 and 22, used for analog and slot 1 digital), and TX Data (Pin 13).

For the RX outputs, there is only 1 which is connected to the accessory connector. RX Audio 1 on pin 7 (to be used for analog and slot 1 digital).

3.5

Station Control Interface

3.5.1

Front Panel Interface Connector

Refer [Modem Interface on page 66](#) for details.

3.5.2

Rear Panel Connections

Refer [USB on page 69](#) to [Auxiliary \(Aux\) on page 71](#) for details.

3.5.3

Power Amplifier Interface Connector

The digital interface to the power amplifier module utilizes a 20 pin vertical LIF connector. See [Figure 8: Modem Module Connector Locations on page 48](#) for the locations of these connectors. [Figure 11: Power Amplifier Interface Connector Pin Locations on page 53](#) shows the pin number locations.

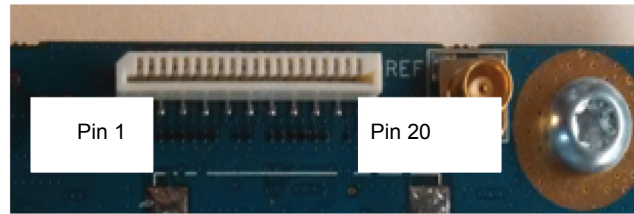
Figure 11: Power Amplifier Interface Connector Pin Locations

3.5.4

Power Supply Interface Connector

The power supply digital interface utilizes a 15 pin Pico-Clasp™ connector. The location is detailed in [Figure 8: Modem Module Connector Locations on page 48](#). [Figure 12: Power Supply Interface Connector Pin Locations on page 53](#) shows the pin number locations.

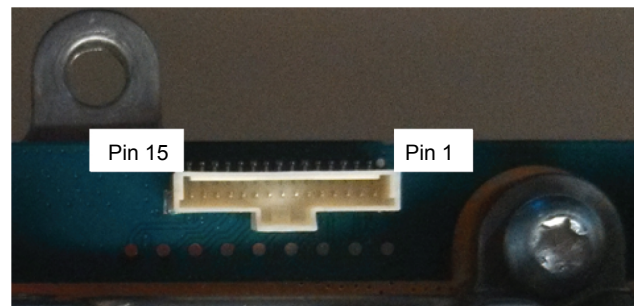
Figure 12: Power Supply Interface Connector Pin Locations

3.5.5

Expansion Board Interface Connector

The expansion board interface utilizes a 30 pin vertical LIF connector. The location is detailed in [Figure 8: Modem Module Connector Locations on page 48](#). [Figure 13: Expansion Board Interface Connector Pin Locations on page 53](#) shows the pin number locations.

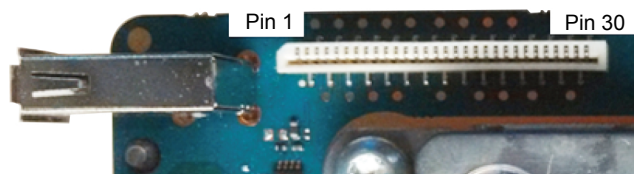
Figure 13: Expansion Board Interface Connector Pin Locations

3.5.6

Chassis ID Interface Connector

The Chassis ID utilizes an 8 pin vertical LIF connector. The location is detailed in [Figure 8: Modem Module Connector Locations on page 48](#). [Figure 14: Chassis ID Interface Connector Pin Locations on page 54](#) shows the pin number locations. The repeater chassis information is necessary for warranty and purchased software features so this must be connected.

Figure 14: Chassis ID Interface Connector Pin Locations

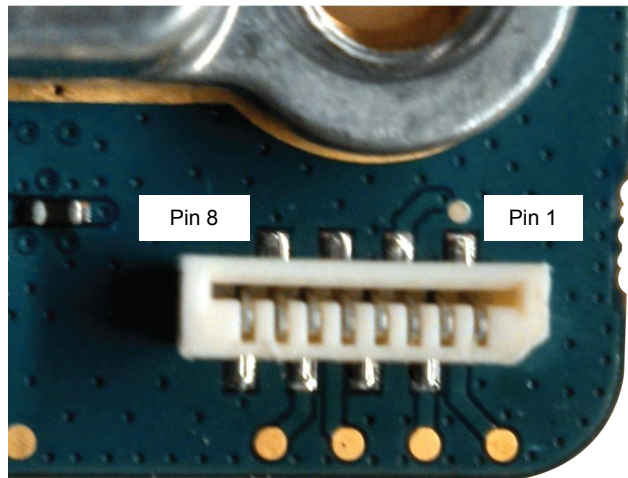

Chapter 4

SLR 5000 Series Power Amplifier

4.1

Description

The Power Amplifier Module is described in this section. A general description, identification of inputs and outputs and functional theory of operation are provided. The information provided is sufficient to give service personnel a functional understanding of the module, allowing maintenance and troubleshooting to the module level.

4.1.1

General Description

The Power Amplifier (PA) is a forced convection-cooled RF power amplifier. It accepts a low-level modulated RF signal from the Exciter Module, and amplifies it for transmission via the site transmit antenna port. The PA is non-linear, and is therefore used for Continuous Wave (CW) applications only. The output power is continually monitored and regulated by a feedback and control loop, with a power output control voltage being generated by the transmitter control circuitry located on the PA. All configuration and control signals are connected to the modem module via the flex connected between the modules.



NOTICE: The power amplifier cooling fan is replaceable and external to the power amplifier itself. See [SLR 5000 Series Maintenance and Disassembly/Reassembly on page 93](#) for replacement details.

4.2

Input and Output Connections

The following figure shows the PA input and output connections.

Figure 15: Input and Output Connections

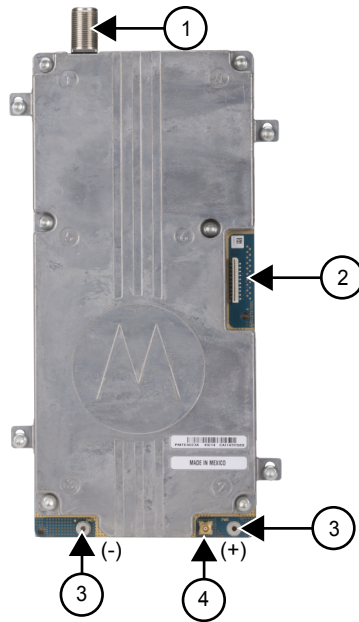

Table 13: Callout Legend

Label	Description
1	Antenna Port
2	Modem Interface
3	DC Input
4	Exciter Input

4.3

Frequency Ranges

The power amplifier modules models cover the following ranges:

- 136–174 MHz
- 400–470 MHz

4.4

Specifications

Specifications of the SLR 5000 series repeater's Power Amplifier (PA) are available in the following table.

Table 14: Specifications of Power Amplifier

Parameter	Specifications	
	VHF	UHF
Operational Frequency Range	136–174 MHz	400–470 MHz
Minimum Input Return Loss (Tx mode)	15 dB	

Table continued...

Parameter	Specifications	
	VHF	UHF
Rated RF Input Power	37 dBm	
Maximum Standby Power Consumption	0.5 W	
Rated RF Output Power Range	1–50 W	
Supply Nominal Voltage ³	13.6 V (+/- 10%)	
Maximum Current Draw ⁴	12.0 A	

4.5

Modem Interface

The digital interface to the modem module utilizes a 20 pin vertical LIF connector. It's location is shown in [Figure 15: Input and Output Connections on page 56](#). See [Figure 16: Modem Interface Connector Pin Locations on page 57](#) for front panel interface connector pin locations.

Figure 16: Modem Interface Connector Pin Locations

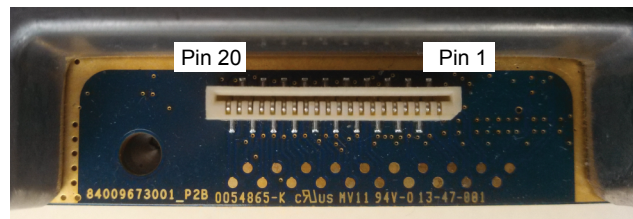

³ When the SLR 5000 series repeater is operating from a DC source, the PA input voltage follows the repeater's DC input source.

⁴ Nominal VSWR conditions (VSWR <1.5:1)

This page intentionally left blank.

Chapter 5

SLR 5000 Series Power Supply

5.1

Description

In this chapter, a general description, performance specifications, and identification of the inputs and outputs are given for the power supply. The information provided is sufficient to give service personnel a functional understanding of the module, allowing maintenance and troubleshooting to the module level. (See [SLR 5000 Series Maintenance and Disassembly/Reassembly on page 93](#) for detailed removal or installation procedures for all modules in the SLR 5000 series repeater.)

5.1.1

General Description

The power supply, with front-to-rear airflow, operates from either an AC or DC input and provides the DC operating voltage for the SLR 5000 series repeater. The power supply also provides an integrated battery charger to maintain the charge on a negatively grounded 12 VDC (nominal) battery system. [Figure 17: Front View of the SLR 5000 Series Power Supply on page 60](#) displays the front and rear views of the SLR 5000 series Power Supply.

Additionally, the power supply affords the following performance features:

- Power Factor Correction (PFC) – aids in lowering the ampacity requirements of the AC power source.
- Over-Voltage Protection (OVP) – lowers the risk of damaging the repeater should input AC or DC levels approach damaging levels.
- Over-Current Protection (OCP) – aids in preventing a cascaded failure within the repeater.
- Reverse Polarity Protection – aids in preventing damage to the repeater due to installation mishaps.
- Configurable Battery Charger Voltage – tailors the float voltage to your battery manufactures charging recommendations.
- Configurable Low Voltage Disconnect (LVD) – tailors the battery disconnect voltage to your battery manufactures recommendations.
- Configurable Power Source Preference – when both AC and DC sources are present (and within their respective operational bounds), this feature allows one to select the primary power source the repeater uses.
- Battery Revert – should the AC source be interrupted, this function allows the power supply to seamlessly transfer to a DC source until the AC source is restored. This results in uninterrupted radio service for as long as DC power can be provided.



NOTICE: A user supplied external 12 V (nominal) battery system is required to support the battery backup feature so that when the AC power fails, the SLR 5000 series repeater can be powered from a DC battery source if it is connected to the PS.



NOTICE: The power supply cooling fan is replaceable and external to the power supply itself. See [SLR 5000 Series Maintenance and Disassembly/Reassembly on page 93](#) for replacement details.

Figure 17: Front View of the SLR 5000 Series Power Supply

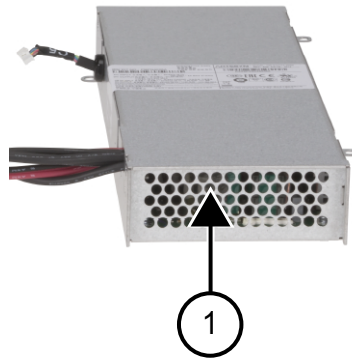

Table 15: Callout Legend

Label	Description
1	Air Intake

Figure 18: Rear View of the SLR 5000 Series Power Supply

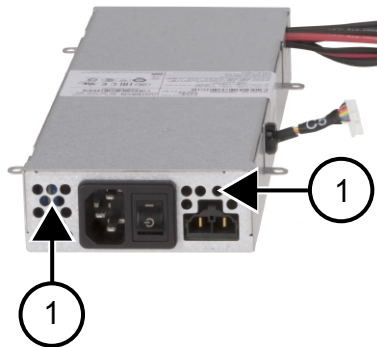

Table 16: Callout Legend

Label	Description
1	Air Exhaust

5.2

Specifications

The following tables show the electrical performance specifications for the Power Supply.

Table 17: Power Supply AC Performance Specifications

Parameter	Value or Range
Input Voltage Range	100–240 VAC
Input Frequency Range	47–63 Hz
Steady State Output Voltage	13.6 ± 0.25 VDC
Output Current (Max)	23 A (excluding charger current)

Table continued...

Parameter	Value or Range
Output Ripple:	30 mVp-p @ 25 °C (77 °F)

Table 18: Power Supply DC Performance Specifications

Parameter	Value or Range
Input Voltage Range	11–15.5 VDC
Steady State Output Voltage	Input voltage dependent (0–0.4 V below input)
Output Current (Max)	26 A
Output Ripple:	30 mV p-p, @ 25 °C (77 °F)

Table 19: Power Supply Battery Charger Performance Specifications

Parameter	Value or Range
Charging Voltage Range	13.5–14.2 VDC (default 13.8 VDC: configurable)
Charging Current (Max)	3 A (in addition to output current)

**NOTICE:**

California Energy Commission (CEC) Compliance testing was performed with the following recommended 12 V Lead-acid battery:

- Sprinter S12V370NGF
- GNB Industrial Power, a division of Exide Technologies, Aurora, Illinois, USA 60504

Charge time may take up to 40 hr.

5.3

Power Supply Interface

5.3.1

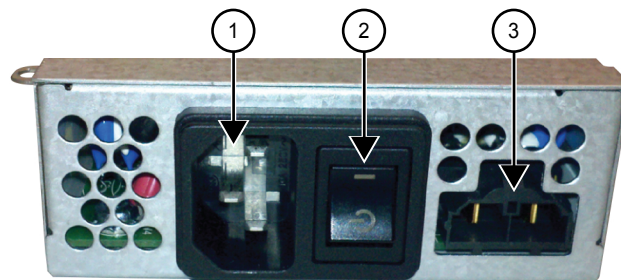
Power Source Inputs**Figure 19: Power Source Inputs**



NOTICE: When the power switch is in standby, all outputs are disabled (regardless of input source(s) connected). This includes the charger output as well (if charging is enabled).

Table 20: Callout Legend

Label	Description
1	AC Source Input Connector
2	Power Switch
3	DC Source Input Connector (also charging output)

5.3.2

Power Supply Outputs

Figure 20: Power Supply Outputs

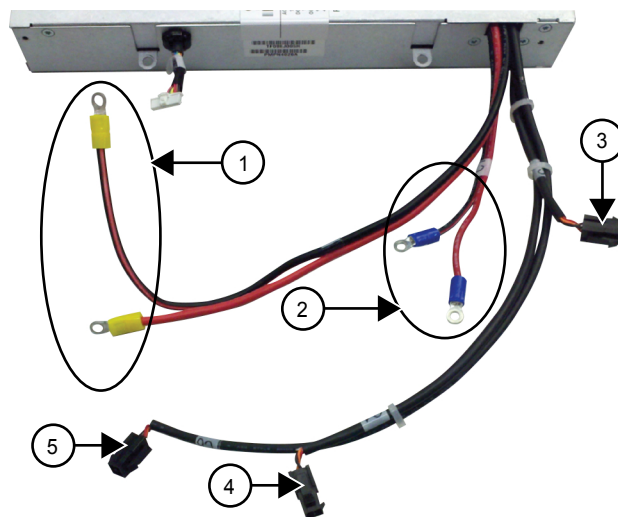

Table 21: Callout Legend

Label	Description
1	Power Amplifier
2	Modem
3	Power Supply Fan
4	Modem Fan
5	Power Amplifier Fan

5.3.3

Power Supply Digital Interface**Figure 21: Power Supply Digital Interface**

Table 22: Callout Legend

Label	Description
1	Modem Interface

5.3.4

Power Supply Output Cable Signaling

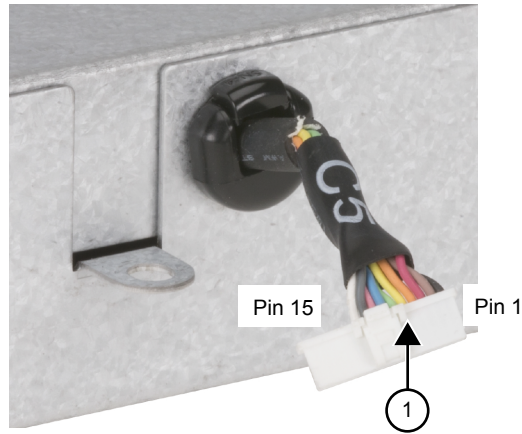
Table 23: Power Supply Output Cable Signaling

Output Load	Signal
Power Amplifier	Red – 13.6 VDC (nominal)
	Black with Red Strip – Ground
Modem	Red – 13.6 VDC (nominal)
	Black with Red Strip - Ground
Power Amplifier Fan	Red – 13.6 VDC (nominal)
	Black – Ground
	Yellow – Fan speed detect
	Brown – Fan speed control
Modem Fan	Red – 13.6 VDC (nominal)
	Black – Ground
	Yellow – Fan speed detect
	Brown – Fan speed control
Power Supply Fan	Red – 13.6 VDC (nominal)
	Black – Ground
	Yellow – Fan speed detect

Table continued...

Output Load	Signal
	Brown – Fan speed control

Chapter 6

SLR 5000 Series Front Panel

6.1

Description

The Front Panel Module is described in this section. A general description, identification of inputs and outputs and functional theory of operation are provided. The information provided is sufficient to give service personnel a functional understanding of the module, allowing maintenance and troubleshooting to the module level.

6.1.1

General Description

The Front Panel board user interface includes 7 LED indicators and a USB device port. The board is connected to the modem via a 30 pin flex cable. The LED indicators inform the user of the state of the repeater while the USB device port is used to interface with the repeater through the Customer Programming Software (CPS). The LED indications are transferred to the front panel via a serial peripheral interface.

6.2

Input and Output Connections

Figure 22: Front Panel Input and Output Connections on page 65 shows the various front panel Input and Output connections.

Figure 22: Front Panel Input and Output Connections

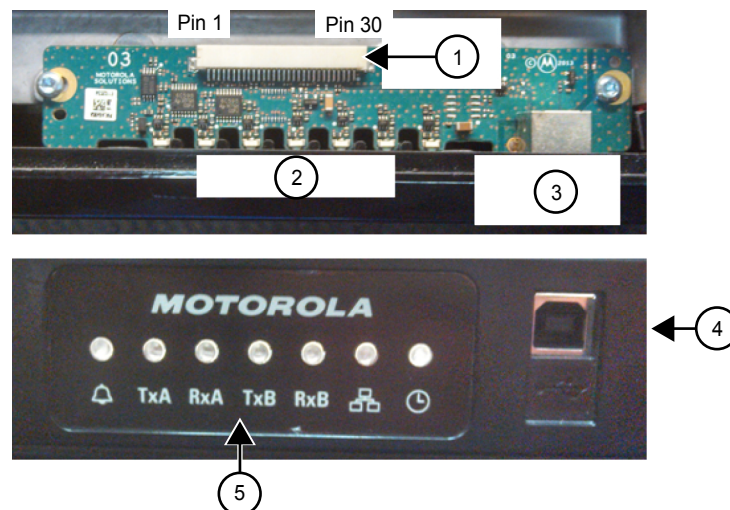

Table 24: Callout Legend

Label	Description
1	Modem Interface
2	LED Indicators

Table continued...

Label	Description
3	USB Device Connector
4	USB Device Connector
5	LED Indicators

6.3

Interfaces

6.3.1

Modem Interface

The interface to the modem is made via a 30 pin flex cable. The connector on the front panel board is a 30 pin horizontal LIF connector. The location can be seen in [Figure 22: Front Panel Input and Output Connections on page 65](#).

6.3.2

User/Service Interface

6.3.2.1

USB

The Front Panel USB device port is the interface used for connecting the repeater to a computer in order to use the Customer Programming Software. See [Figure 22: Front Panel Input and Output Connections on page 65](#) for the location. A standard “Type A” to “Type B” USB cable facilitates the connection. See [Appendix A : Accessories on page 129](#), [Service Tools on page 131](#) for the noted USB cable part number.

6.3.2.2

LED Indicators

The Front Panel houses 7 LED indicators used for displaying the state of the repeater. For state details, refer to [Table 9: SLR 5000 Series Front Panel LED Definitions on page 42](#).

Chapter 7

SLR 5000 Series Back Panel

7.1

Description

The Back Panel interface provides the electrical interconnection interface between the SLR 5000 series repeater and the end user's system. This includes the connectors necessary to interface the repeater to RF peripheral equipment, power system, system controllers, LANs, as well as other communications and maintenance equipment. This section provides a general description, identification of inputs/ outputs, and a pin-out listing for all connectors, including information on signal names, functions, and levels.

7.1.1

General Description

Figure 23: Back Panel Connector Names and Locations on page 67 shows the various interface connector locations. Table 25: Connector Type and Primary Function on page 67 lists the connector types as well as its primary function.

Figure 23: Back Panel Connector Names and Locations

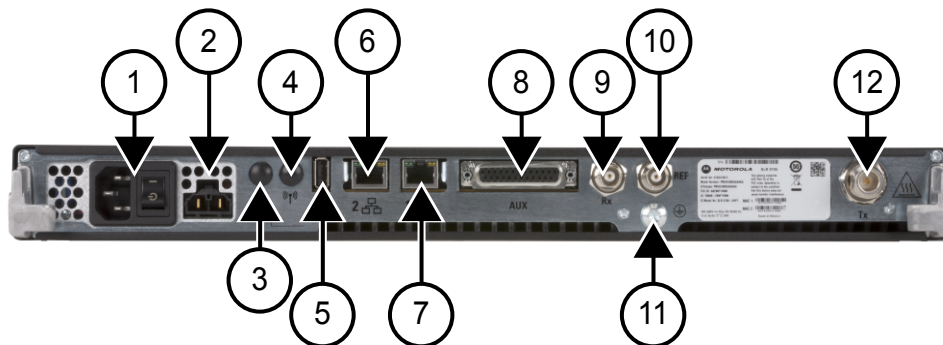

Table 25: Connector Type and Primary Function

Location	Connector Type	Function(s)
1	C14 (IEC 60320)	AC Power Inlet and Repeater Power Switch
2	Molex 42818-0212	DC Power Inlet and DC Charger Outlet
3	Option Dependent	Option Dependent 1
4	Option Dependent	Option Dependent 2
5	Type A Socket	USB
6	RJ-45 – Jack	Ethernet 2
7	RJ-45 – Jack	Ethernet 1
8	DB25 – Female	Aux: Rx Audio, Tx Audio, PTT, COR, Accessory Power, 1 PPS, and GPIO

Table continued...

Location	Connector Type	Function(s)
9	BNC – Female	Receiver RF (Rx)
10	BNC – Female	Frequency Reference Input (REF)
11	T30 TORX Screw	Bonding Ground Connection
12	N-Type – Female	Transmitter RF (Tx)

7.2

Back panel Interfaces

7.2.1

AC Power Inlet

The AC power inlet connector is of the C14 type socket (IEC 60320) and accepts interface to C13 type plugged (IEC 60320) power cords. [Figure 24: AC Power Inlet Connector on page 68](#) shows the location of the pins and [Table 26: AC Power Inlet Connector on page 68](#) lists the functional characteristics of the connector's pins.

Figure 24: AC Power Inlet Connector

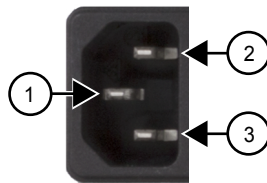

Table 26: AC Power Inlet Connector

Location	Pin Assignment	Type	Signal Characteristics
1	Earth	Power	100–240VAC (Line to Neutral)
2	Line		4 A (max)
3	Neutral		

Figure 25: Repeater Power Switch

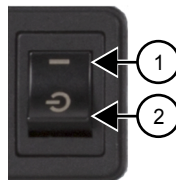

Table 27: Callout Legend

Label	Description
1	ON (fully powered)
2	STANDBY

7.2.2

DC Power Inlet/DC Charger Outlet

The DC power inlet/DC charger outlet connector is a Molex 42818-02012 panel mount receptacle and accepts interface to Molex 42816-0212 plugs. [Figure 26: DC Power Inlet/DC Charger Outlet Connector on page 69](#) shows the location of the pins and [Table 28: DC Power Inlet/DC Charger Outlet Connector on page 69](#) lists the functional characteristics of the connector's pins.

Figure 26: DC Power Inlet/DC Charger Outlet Connector

Table 28: DC Power Inlet/DC Charger Outlet Connector

Location	Pin Assignment	Type	Signal Characteristics
1	Positive	Power	11–14.4VDC
2	Negative		17 A (max)

7.2.3

Option 1/GNSS

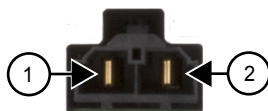
Not supported at this time (No connection)

Figure 27: Option 1/GNSS Connector

7.2.4

Option 2/WLAN

Not supported at this time (No connection)

Figure 28: Option 2/WLAN Connector

7.2.5

USB

Not supported at this time. Type A socket (Host Connection) that supports the USB 2.1 protocol standard. See the following figure and table for location of the pins and the functional characteristics of the connector's pins.

Figure 29: USB Connector

Table 29: USB Connector

Location	Pin Assignment	Type	Signal Characteristics
1	VBUS		+5 VDC
2	D-	USB Physical Layer	3.6 V differential data
3	D+		
4	GND		Ground

7.2.6

Ethernet 1

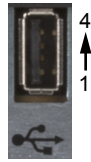
Fully compliant with IEEE and 802.3 and 802.3u standards. Supports 10Base-T, 100Base-Tx rates, full duplex, half duplex mode and flow control. See the following figure and table for location of the pins and the functional characteristics of the connector's pins.

Figure 30: Ethernet 1 Connector

Table 30: Ethernet 1 Connector

Location	Pin Assignment	Type	Signal Characteristics
1	Ethernet Tx+	Ethernet Physical Layer	5 V differential data
2	Ethernet Tx-		
3	Ethernet Rx+		
4	Unused		N/A
5	Unused		N/A
6	Ethernet Rx-		5 V differential data
7	Unused		N/A
8	Unused		N/A

7.2.7

Ethernet 2

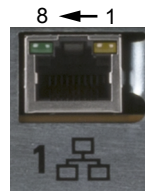
Not supported at this time. Fully compliant with IEEE and 802.3 and 802.3u standards. Supports 10Base-T, 100Base-Tx rates, full duplex, half duplex mode and flow control. See the following figure and table for location of the pins and the functional characteristics of the connector's pins.

Figure 31: Ethernet 2 Connector

Table 31: Ethernet 2 Connector

Location	Pin Assignment	Type	Signal Characteristics
1	Ethernet Tx+	Ethernet Physical Layer	5 V differential data
2	Ethernet Tx-		5 V differential data
3	Ethernet Rx+		5 V differential data
4	Unused		N/A
5	Unused		N/A
6	Ethernet Rx-		5 V differential data
7	Unused		N/A
8	Unused		N/A

7.2.8

Auxiliary (Aux)

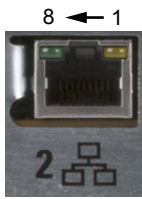
This connection supports the analog interface to the SLR 5000 series repeater, which includes audio, station control, station indicators, accessory power, and provisions for timing used in various system implementations. See the following figure and table for location of the pins and the functional characteristics of the connector's pins.

Figure 32: Auxiliary Connector

Table 32: Auxiliary Connector

Location	Pin Assignment	Type	Signal Characteristics
1	Tx Audio 1	Audio	Transmit Audio – Nominal input level is 80 mVrms for 60% deviation with scaling factor set to 100%. 600 Ω input impedance.
2	GPIO 1	Digital	Output Logic Low: 0.5 VDC max Output Logic High: Open Collector with 10 k pull-up to 5 V Input Logic Low: 0–0.8 VDC Input Logic High: 3.0–14 VDC

Table continued...

Location	Pin Assignment	Type	Signal Characteristics
3	Rx Audio 2 ⁵	Audio	Receiver Audio – Nominal output level is 330 mVrms (into a 50 k Ohm load) with a 60% deviation receive signal. 1000 Ω output impedance.
4	GPIO 2	Digital	Output Logic Low: 0.5 VDC max Output Logic High: Open Collector with 10 k pull-up to 5 V Input Logic Low: 0–0.8 VDC Input Logic High: 3.0–14 VDC
5	GPIO 10/Analog Input 2 ⁵	Digital	Output Logic Low: 0.5 VDC max Output Logic High: Open Collector with 10 k pull-up to 5 V Input Logic Low: 0–0.8 VDC Input Logic High: 3.0–14 VDC Analog: 0–5 VDC
6	GPIO 9/Analog Input 1 ⁵	Digital	Output Logic Low: 0.5 VDC max Output Logic High: Open Collector with 10 k pull-up to 5 V Input Logic Low: 0–0.8 VDC Input Logic High: 3.0–14 VDC Analog: 0–5 VDC
7	Rx Audio 1	Audio	Receiver Audio – Nominal output level is 330 mVrms (into a 50 k Ohm load) with a 60% deviation receive signal. 1000 Ω output impedance.
8	GPIO 6	Digital	Receiver Audio – Nominal output level is 330 mVrms with a 60% deviation receive signal. 1000 Ω output impedance.
9	Ground		
10	GPIO 7/Analog RSSI Out ⁵	Digital or Analog	Digital: Output Logic Low: 0.5 VDC max Output Logic High: Open Collector with 10 k pull-up to 5 V Input Logic Low: 0–0.8 VDC Input Logic High: 3.0–14 VDC Analog RSSI: Typically 0.5 VDC for -120 dBm to 2.7 VDC for -60 dBm carrier. Variation with carrier level at approximately 50 mV/dBm.
11	GPIO 11/Analog Input 3 ⁵	Digital or Analog	Digital: Output Logic Low: 0.5 VDC max Output Logic High: Open Collector with 10 k pull-up to 5 V Input Logic Low: 0–0.8 VDC Input Logic High: 3.0–14 VDC Analog: 0–5 VDC

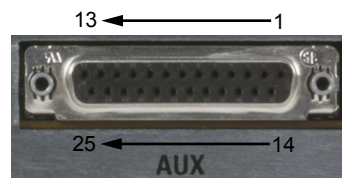
Table continued...

⁵ Not supported in initial release.

Location	Pin Assignment	Type	Signal Characteristics
12	GPIO 12/Analog Input 4 ⁵	Digital or Analog	Digital: Output Logic Low: 0.5 VDC max Output Logic High: Open Collector with 10 k pull-up to 5 V Input Logic Low: 0–0.8 VDC Input Logic High: 3.0–14 VDC Analog: 0–5 VDC
13	Tx Data	Digital or Analog	Transmit Data/PL/DPL – Nominal input level is 80 mVrms for 20% deviation with scaling factor set to 100%. 600 Ω input impedance.
14	1 PPS In ⁵ /Out	Digital	Output Logic Low: 0.5 VDC max Output Logic High: Open Collector with 10 k pull-up to 5 V Input Logic Low: 0–0.8 VDC Input Logic High: 3.0–14 VDC
15	GPIO 3	Digital	Output Logic Low: 0.5 VDC max Output Logic High: Open Collector with 10 k pull-up to 5 V Input Logic Low: 0–0.8 VDC Input Logic High: 3.0–14 VDC
16	Ground		
17			
18			
19			
20	Fused B+	Power	The B+ is 13.6 VDC when repeater is sourced by AC, and can range from 11–14.4 VDC when sourced by DC. 1 A (max).
21	GPIO 8/Analog Output 2 ⁵	Digital or Analog	Digital: Output Logic Low: 0.5 VDC max Output Logic High: Open Collector with 10 k pull-up to 5 V Input Logic Low: 0–0.8 VDC Input Logic High: 3.0–14 VDC Analog: 0–5 VDC
22	Tx Audio 1	Audio	Transmit Audio – Nominal input level is 80 mVrms for 60% deviation with scaling factor set to 100%. 600 Ω input
23	GPIO 4	Digital	Output Logic Low: 0.5 VDC max Output Logic High: Open Collector with 10 k pull-up to 5 V Input Logic Low: 0–0.8 VDC Input Logic High: 3.0–14 VDC
24	GPIO 5	Digital	Output Logic Low: 0.5 VDC max Output Logic High: Open Collector with 10 k pull-up to 5 V Input Logic Low: 0–0.8 VDC

Table continued...

Location	Pin Assignment	Type	Signal Characteristics
			Input Logic High: 3.0–14 VDC
25	Tx Audio 2 ⁵	Audio	Transmit Audio – Nominal input level is 80 mVrms for 60% deviation with scaling factor set to 100%. 600 Ω input

7.2.9

Frequency Reference

The Frequency Reference port is a BNC (female) type connector. [Figure 33: Frequency Reference Connector on page 74](#) depicts the Frequency Reference connector.

Figure 33: Frequency Reference Connector



Various external frequency reference signal types can be provided to the SLR 5000 series repeater for normal operation. [Table 33: Frequency Reference on page 74](#) provides a list of acceptable input signal types as well as their permissible levels.

Table 33: Frequency Reference

Frequency (MHz)	Waveform ⁶	Level (Vpp)	Impedance (Ω) ⁷	Note
5	Sine	1.5–5.3	100 k	AC Coupled
5	Square ⁶	1.5–5.3	100 k	AC Coupled
10	Sine	1.5–5.3	100 k	AC Coupled
10	Square ⁶	1.5–5.3	100 k	AC Coupled

7.2.10

Receiver RF

The Receiver RF port is a BNC (female) type connector. [Figure 34: Receiver RF Connector on page 74](#) depicts the Receiver RF connector.

Figure 34: Receiver RF Connector



7.2.11

Transmitter RF

The Transmitter RF port is an N-Type (female) type connector. [Figure 35: Transmitter RF Connector on page 75](#) depicts the Transmitter RF connector.

⁶ Square wave duty cycle range is 45–50%.

⁷ Impedance of the SLR 5000 series repeater's frequency reference port.

Figure 35: Transmitter RF Connector

7.2.12

Bonding Ground Connection

The repeater Bonding Ground Connection is realized with an M6 x 1 x 3 mm screw (T30 Torx). [Figure 36: Bonding Ground Connection on page 75](#) depicts the Bonding Ground Connection.

Figure 36: Bonding Ground Connection

This page intentionally left blank.

Chapter 8

SLR 5000 Series Test Equipment And Service Aids

8.1

Recommended Test Equipment

The list of equipment includes most of the standard test equipment required for servicing Motorola SLR 5000 series repeaters.

Table 34: Recommended Test Equipment

Equipment	Example	Application
Service Monitor	Aeroflex 3920 Digital Radio Test Set or equivalent ⁸ (www.aeroflex.com)	Frequency/deviation meter, signal generator, oscilloscope, RF power meter for wide-range troubleshooting and alignment.
Digital RMS Multimeter	Fluke 179 or equivalent (www.fluke.com)	AC/DC voltage measurements

8.2

Service Aids

[Service Tools on page 131](#) lists the service aids recommended for working on the SLR 5000 series repeater. While all of these items are available from Motorola Solutions, most are standard workshop equipment items, and any equivalent item capable of the same performance may be substituted for the item listed.

⁸ Equivalency can be established with "all-in-one" service monitors and/or the individual functional components of a service monitor (such as RF Signal Generator, RF Spectrum Analyzer, RF Deviation Meter, RF Power Meter, and oscilloscope).

This page intentionally left blank.

Chapter 9

SLR 5000 Series Performance Check or Testing

9.1

General

The SLR 5000 series repeater meets published specifications through the manufacturing process by utilizing high-accuracy laboratory-quality test equipment. The recommended field service equipment approaches the accuracy of the manufacturing equipment with few exceptions. This accuracy must be maintained in compliance with the equipment manufacturer's recommended calibration schedule.



NOTICE: Although these repeaters function in digital and analog modes, all testing is done in analog mode. Digital Repeater tests can be performed using an Aeroflex 3900 Series Service Monitor, if the DMR Digital Repeater Test Option is purchased. This auto testing could be performed in lieu of the Manual testing described below.

9.2

Transmitter Testing



CAUTION: The repeater needs to be taken out of service in order to carry out performance testing procedures. Unless the repeater is already out of service, it is recommended to perform the procedures during off-peak hours in order to minimize disruption of service to the system subscribers.

9.2.1

Introduction

While most module faults can be detected by running the repeater diagnostics, the following procedure provides a more traditional method of troubleshooting the transmitter circuitry.

This procedure allows the service technician to make minor adjustments and verify proper operation of the repeater transmit circuitry, including:

- Exciter Section of Modem Module
- Power Amplifier Module
- Power Supply Module

In general, the transmitter circuitry is exercised by injecting and measuring signals using a Service Monitor (or equivalent). Incorrect measurement values indicate a faulty module(s); measurement values within the acceptable range verify proper operation of the above listed modules and circuitry.

9.2.2

Test Equipment

The following test equipment are required to perform the procedure:

- Aeroflex 3920 Digital Radio Test Set (or equivalent)
- Microphone (GMMN4063_)
- Power Meter and Sensor
- Station Rear Accessory Test Cable

- Dummy Load (50 Ω , repeater wattage or higher)

9.2.3

Verifying Transmitter Circuitry Procedure

Procedure:

- 1 Connect and set up test equipment as shown in [Figure 37: Test Equipment Setup for Verifying Transmitter Circuitry on page 81](#).
- 2 Apply input power (AC or DC) to the repeater. The power supply, modem and PA fans should run a few seconds to confirm fan operation.
- 3 Press the PTT switch of the microphone and observe the PA Keyed LED indicator on the Repeater Front Panel.
If PA Keyed fails to light, suspect the following:
 - Faulty Power Amplifier Module
 - Faulty Modem Module
 - Loose or bad Exciter-to-PA RF cable
 - Loose or bad PA-to-antenna RF output cable
 - Improperly terminated PA RF output cable
 - Faulty Power Supply Module
- 4 Measure output power by pressing the PTT button and observing reading on an in-line wattmeter.
 - If PA output is not at proper power (as set for particular site), adjust the output power as described in the CPS online help.
- 5 If PA output power is proper, set up the Service Monitor for spectrum analyzer display. Press the PTT button and observe the display. The display should show a single frequency carrier:
 - If the display shows multiple carriers evenly spaced about the carrier, suspect a faulty Exciter module or PA module.
 - If the display shows a solid carrier but it is off frequency, suspect the following:
 - Faulty Modem Module
 - Faulty external 5/10 MHz reference source (if used)
 - If the display shows a single carrier moving erratically, suspect a faulty Modem Module.
- 6 If display is proper, set up Aeroflex 3900 Series Communications System Analyzer to display modulation. Using the microphone, push the PTT button and speak into the microphone. Verify that the display shows an audio signal.
 - If the proper display is not obtained, suspect faulty SCM or Exciter Module
- 7 Set the Aeroflex 3900 Series Communications System Analyzer for GEN/ MON MTR. Press the PTT button and speak loudly into the microphone to cause maximum deviation. Display should read:
 - 4.60 kHz maximum for a 25 kHz system
 - 3.68 kHz maximum for a 20 kHz system
 - 2.30 kHz maximum for a 12.5 kHz systemIf the proper display is not obtained, suspect faulty SCM or Exciter Module.
- 8 This completes the Verifying Transmitter Circuitry test procedure. If all displays and measurements are correct, the transmitter circuitry may be considered to be operating properly.

Figure 37: Test Equipment Setup for Verifying Transmitter Circuitry

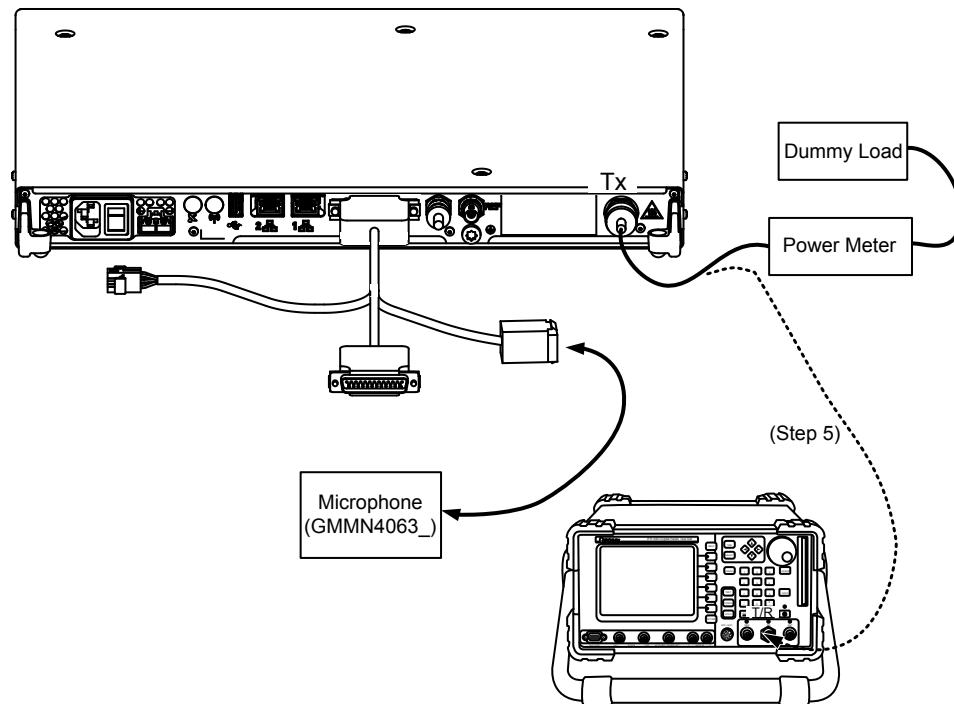

9.3

Receiver Testing

**CAUTION:**

Performing this procedure requires that the repeater be taken out of service. It is recommended that, unless the repeater is already out of service, this procedure be performed during off-peak hours so as to minimize the disruption of service to the system subscribers.

If the repeater operates as a repeater, the transmit output from the repeater must be connected to a dummy load to prevent over-the-air broadcast during Receiver testing.

9.3.1

Introduction

While most module faults can be detected by running the repeater diagnostics, the following procedure provides a more traditional method of troubleshooting the Receiver circuitry.

This procedure allows the service technician to make minor adjustments and verify proper operation of the repeater receive circuitry on the Modem Module.

In general, the Receiver circuitry is exercised by injecting and measuring signals using a Service Monitor (or equivalent). Incorrect measurement values indicate a faulty module(s); measurement values within the acceptable range verify proper operation of the receiver circuitry on the Modem Module.

9.3.2

Required Test Equipment

The following test equipment are required to perform the procedure:

- Aeroflex 3920 Digital Radio Test Set (or equivalent)
- Service Speaker (part no. HSN1006_)

Motorola Solutions Confidential

- Station Rear Accessory Test Cable
- Dummy Load (50 Ω , repeater wattage or higher) required for repeaters only

9.3.3

Verifying Receiver Circuitry Procedure

Procedure:

- 1 Connect equipment as shown in [Figure 38: Test Equipment Setup for Verifying Receiver Circuitry on page 83](#).
- 2 Set the Service Monitor to generate a 1.0 μ V (-107 dBm) FM signal at the Receiver frequency, modulated by a 1 kHz tone at 3 kHz deviation for 25 /30 kHz channel spacing, or 1.5 kHz deviation for 12.5 kHz channel spacing. The 1 kHz tone should be audible through the external speaker. If no audio is heard, suspect the following:
 - Faulty Modem Module
 - Faulty antenna-to-Receiver preselector RF cable (for the repeater with external metal preselector)
 - Faulty Service Monitor-to-station RF cable
 - Faulty Antenna Relay (If installed)
 - Faulty Preselector (If installed)
 - Rear Panel to Modem Module cable unplugged
 - Faulty rear panel to Modem Module Cable
- 3 If Audio is heard (the audio volume can be adjusted on the rear of the HSN1006), look at the Oscilloscope window on the Aeroflex 3920 (or a separate O-Scope) and verify that the Audio level Sine Wave measures between 0.75 to 1.5 Vpp. If not, connect to Tuner and increase the RX Audio level until this is achieved. If the level cannot be obtained, suspect a faulty Modem.
- 4 Move the BNC cable from the Scope CH 1 input to the Audio 1 input.
- 5 Change System Monitor injection signal level to the noted levels in .
- 6 Measure the Receiver 12 dB SINAD sensitivity.
 - If the SINAD level is less than 12 dB, suspect faulty Modem.
- 7 This completes the Verifying Receiver Circuitry test procedure. If all displays and measurements are correct, the Receiver circuitry may be considered to be operating properly. Remove test equipment, restore the repeater to normal service, and (if applicable) return to the troubleshooting flow chart to resume troubleshooting sequence.

Figure 38: Test Equipment Setup for Verifying Receiver Circuitry

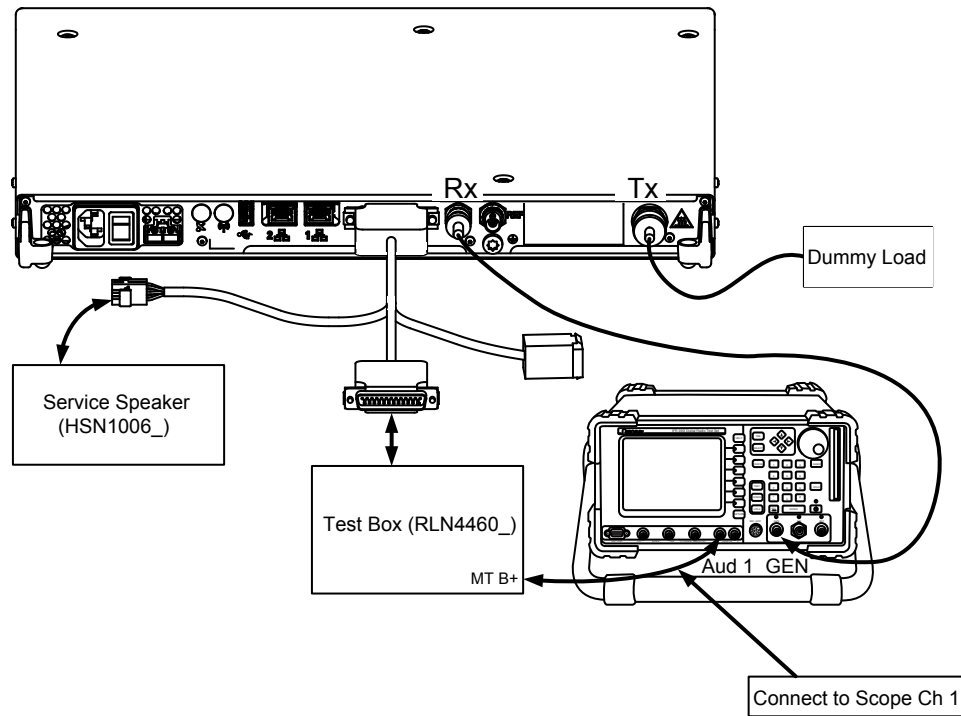

9.4

Auto Test and Tune Support

Auto Test and Tune Support is an automated alignment procedure for the repeater.

This procedure allows you to perform Test and Tune in the right method that saves time and helps to achieve higher efficiency.

To accomplish the overall Test and Tune procedure, the repeater must be tested in two test suites: Analog mode and Digital mode. This procedure includes Tuning and Testing in Analog mode and Testing in Digital mode.



NOTICE: Contact Motorola Solutions Customer Support for more details on this procedure.

This page intentionally left blank.

Chapter 10

SLR 5000 Series Programming and Tuning

10.1

Introduction

This chapter provides an overview of the MOTOTRBO Customer Programming Software (CPS) and the MOTOTRBO Tuner application for use on Windows 7™, Windows 8™, or Windows 8.1™. These two MOTOTRBO applications are used for the configuration and alignment of the SLR 5000 series repeater.

10.2

Customer Programming Software Setup

The Customer Programming Software setup, shown in [Figure 39: Customer Programming Software Setup on page 85](#) is used to program the repeater. See [Figure 40: Front view of SLR 5000 Series Repeater on page 86](#) and [Figure 41: Rear view of SLR 5000 Series Repeater on page 86](#) for the actual connectors on the front and rear panels of the repeater.



NOTICE: See appropriate program on-line help files for the programming procedures.



CAUTION: Computer USB ports can be sensitive to Electronic Discharge. Employ proper ESD practices (wrist strap, grounding, etc.) and do not touch exposed contacts on cables when connected to a computer.

Figure 39: Customer Programming Software Setup

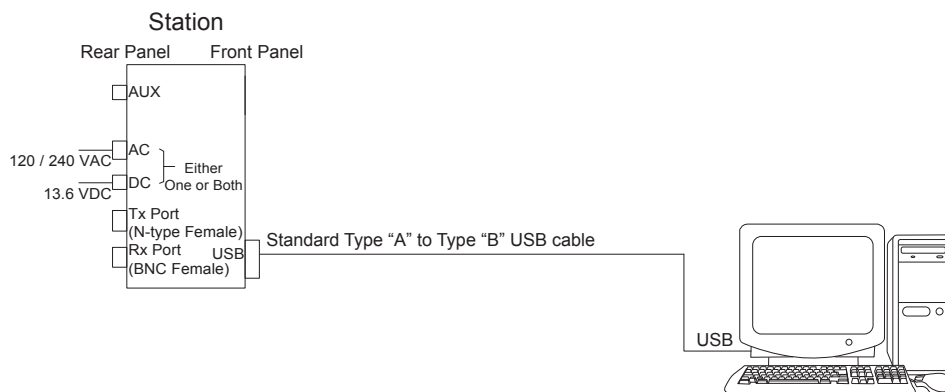

Figure 40: Front view of SLR 5000 Series Repeater

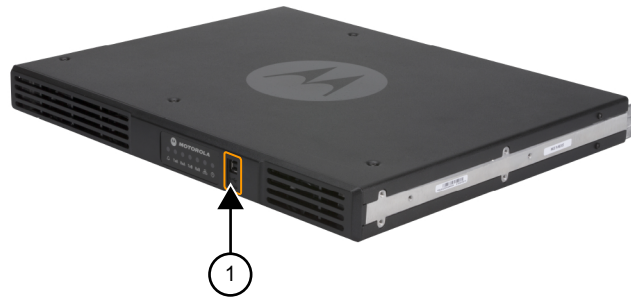

Table 35: Callout Legend

Label	Description
1	USB Port

Figure 41: Rear view of SLR 5000 Series Repeater

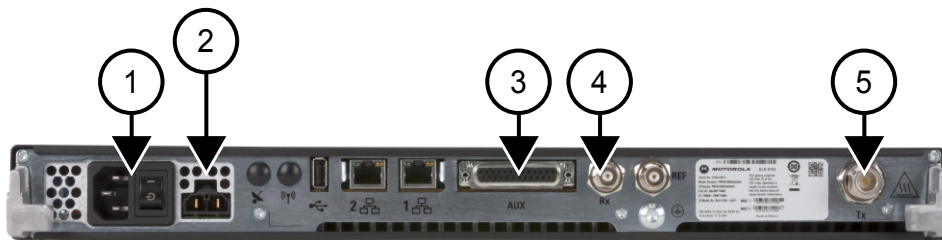

Table 36: Callout Legend

Label	Description
1	AC Inlet Connector
2	DC Inlet Connector
3	Aux Connector
4	Rx RF Connector
5	Tx RF Connector

10.3

Reference Oscillator Alignment

This feature is used to adjust the reference oscillator of the repeater. This alignment process should be done as maintenance schedules and regulations require or if the Modem FRU has been replaced in the repeater.

10.3.1

Tuning Procedure

Procedure:

- 1 Connect the repeater's transmitter antenna port to the Communication Analyzer.

- 2 Power the repeater from either an AC or DC source.
- 3 Click the “Read” button in the tuner to begin reading the repeater’s tuning softpot values.
- 4 Select “Ref Oscillator” under the TX menu in the tree view (See [Figure 42: Tx Menu Tree \(Ref. Oscillator\)](#) on page 87).

Figure 42: Tx Menu Tree (Ref. Oscillator)

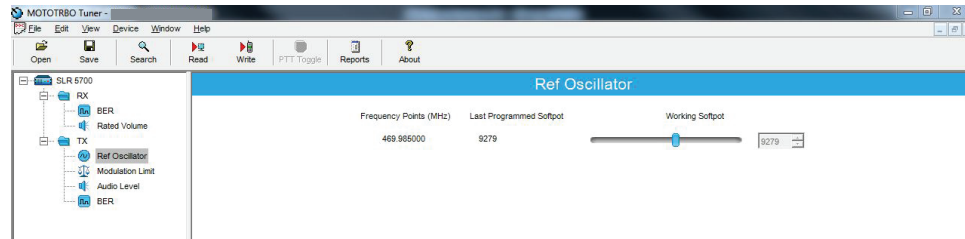

- 5 Configure the current operating frequency into the Communications Analyzer.
- 6 Click the “PTT Toggle” button to key up the repeater.
- 7 Adjust the working softpot value until the frequency is within the performance specifications (+/- 40 Hz for UHF and VHF) from the frequency point.
- 8 Click the “PTT Toggle” button to de-key the repeater.
- 9 Click the “Write” button to save the tuned softpot value into the repeater codeplug.

10.4

Repeater Tuning Setup

A personal computer (PC), Windows™ operating system, and the MOTOTRBO Tuner application are required to align the repeater. To perform the tuning procedures, the repeater must be connected to the PC and test equipment setup as shown in [Figure 43: SLR 5000 Series Repeater Tuning Equipment Setup](#) on page 87.

Figure 43: SLR 5000 Series Repeater Tuning Equipment Setup

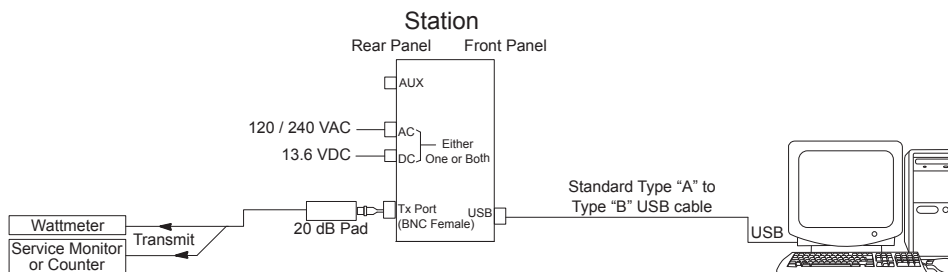

10.5

Rx Audio Level Set

The procedure outlined in this section is used to set the receive output audio level from the repeater for a given RF deviation of the received RF signal. Perform this procedure any time the Rx audio level needs adjustment.

10.5.1

Tuning Procedure

Procedure:

- 1 Connect the repeater’s receiver antenna port to the Communication Analyzer.

Motorola Solutions Confidential

- 2 Power the repeater from either an AC or DC source.
- 3 Launch the Tuner application and click the "Read" button to read the softpot values.
- 4 Select "Rx Rated Volume" under the Rx menu in the tree view.

Figure 44: Rx Menu tree (Rx Rated Volume)

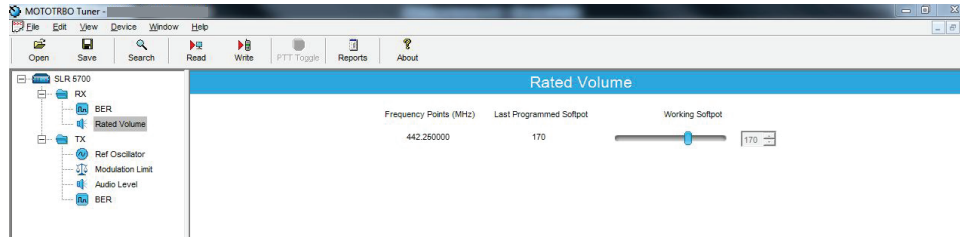

- 5 Set the Communication Analyzer to output a -47 dBm RF signal modulated with a 1 kHz tone at 60% of full deviation on the tuning frequency. The tuning frequency is the value displayed on the Tuner GUI under the heading of "Frequency Points".



NOTICE:

The Tuner aligns this parameter in a 12.5 kHz channel spacing, so 60% is 1.5 kHz of deviation. If the CPS is set for 25 kHz operation, the repeater will automatically scale the deviation by a factor of two when it is outside the Tuner environment.

Programmed TPL and DPL squelch requirements are automatically disabled for the tuning frequency while in the Tuner environment.

- 6 Adjust the softpot value until the desired receive audio level is achieved at pin #7 (in reference to ground) on the Aux connector Ground connections provided by the Aux connector are pins: 9, 16, 17, 18, and 19.

Figure 45: Auxiliary Connector

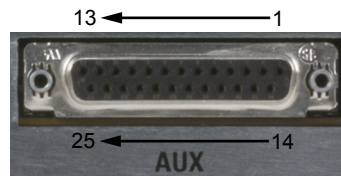

NOTICE: Optimally, it is recommended to load pin #7 with application loading used during normal operation of the repeater.

- 7 Click "Write" to save the new tuned softpot value into the repeater's codeplug.

10.6

Tx Audio Level Set

The procedure outlined in this section is used to allow adjustment of the transmitter audio level the repeater is expecting at its Aux connector. Adjusting this level set has the effect of increasing or decreasing RF signal deviation for a given transmit audio level. Perform this procedure any time the transmitter audio level needs adjustment.

10.6.1

Tuning Procedure

Procedure:

- 1 Connect the repeater's transmitter antenna port to the Communication Analyzer.
- 2 Power the repeater from either an AC or DC source.

- 3 Apply a 1 kHz signal at the desired input level to pin #1 or #22 (in reference to ground) on the Aux connector. Ground connections provided by the Aux connector are pins: 9, 16, 17, 18, and 19. See [Figure 45: Auxiliary Connector on page 88](#).



NOTICE: Optimally, it is recommended to load pin #1 or #22 with the application source impedance used during normal operation of the repeater.

- 4 Launch the Tuner application and click the “Read” button to read the softpot values.
- 5 Select “Tx Audio Level” under the Tx menu in the tree view (See [Figure 46: Tx Menu Tree \(Tx Audio Level\) on page 89](#)).

Figure 46: Tx Menu Tree (Tx Audio Level)

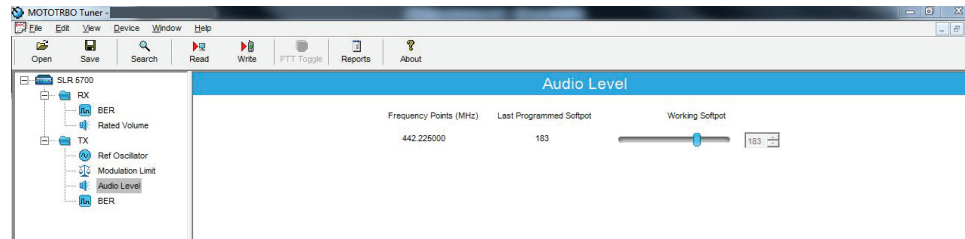

- 6 Enter the tuning frequency into the Communication Analyzer (the value displayed on the Tuner GUI under the heading of “Frequency Points”).
- 7 Click the “PTT Toggle” button within the Tuner environment to key up the repeater.
- 8 Adjust the softpot value until 60% of the rated system deviation (RSD) is achieved.
 -  **NOTICE:** The Tuner aligns this parameter in a 12.5 kHz channel spacing, so 60% is 1.5 kHz of deviation. If the CPS is set for 25 kHz operation, the repeater will automatically scale the deviation by a factor of two when it is outside the Tuner environment.
- 9 Click the “PTT Toggle” button within the Tuner environment to de-key the repeater.
- 10 Click “Write” to save the new tuned softpot value into the repeater’s codeplug.

10.7

Modulation Limit Alignment

This feature is to set the modulation limit of the SLR 5000 Series Repeater.



NOTICE: A modulation limit alignment is not needed if the repeater is used in repeat mode. This is always the case when the repeater is in digital mode.

10.7.1

Tuning Procedure (with no Tx Data and no PL)

Prerequisites:



NOTICE: If data or PL signaling is applied to Pin 13 of the J7 connector, proceed to [Tuning Procedure \(with Tx Data or PL\) on page 91](#).

Procedure:

- 1 Connect the repeater’s antenna port to the attenuation pad, if necessary, before connecting to the Communication Analyzer.
- 2 Power the repeater from either an AC or DC source.
- 3 Apply a 1 kHz signal at 1.2 Vrms to Pin 1 of the J7 backplane connector.
 - Signal ground is Pin 9 of the J7 backplane connector.
- 4 Launch the Tuner application and click the “Read” button to read the softpot values.

Motorola Solutions Confidential

- 5 Select “Modulation Limit” under the Tx menu in the tree view (See [Figure 47: Tx Menu tree \(Tuning Procedure with no Tx data\)](#) on page 90).

Figure 47: Tx Menu tree (Tuning Procedure with no Tx data)

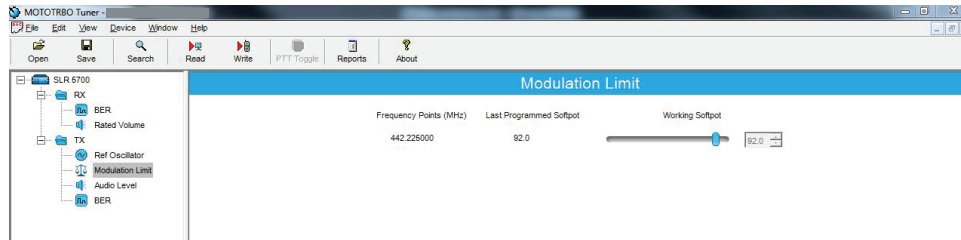

- 6 Enter the tuning frequency into the Communication Analyzer (the value displayed on the Tuner GUI).
- 7 Click the “PTT Toggle” button within the Tuner environment to key up the repeater.
- 8 Adjust the softpot value until the maximum deviation is 92% of the rated system deviation (RSD). This will be tested in a 12.5 kHz channel spacing, so 92% of 2.5 kHz is 2.3 kHz.

 **NOTICE:** Set the modulation limit to 92% so that any additional deviation incurred by the transmitter VCOs over temperature is compensated for.

Channel Spacing (kHz)	RSD (kHz)	92% of RSD (kHz)	Tolerance (Hz)
12.5	2.5	2.3	+0/ -50

- 9 Click the “PTT Toggle” button within the Tuner environment to de-key the repeater.
- 10 Click “Write” to save the new tuned softpot value into the repeater’s codeplug.

10.7.2

Verification (with no Tx Data and no PL)

Procedure:

- 1 Connect the repeater's antenna port to the attenuation pad, if necessary, before connecting to the Communication Analyzer.
- 2 Power the repeater from either an AC or DC source.
- 3 By using CPS, program the repeater with any frequency within the specified range of the repeater under test, and set the repeater for low power and disable the repeat path.
- 4 Apply a 1 kHz signal at 1.2 Vrms to Pin 1 of the J7 backplane connector.
 - Signal ground is Pin 9 of the J7 backplane connector.
- 5 Key up the repeater and measure the deviation
 - Key the repeater by grounding Pin 2 of the J7 backplane connector.

 **NOTICE:** CPS must have Pin 2 configured as an active low with the PTT function.

- 6 De-key the repeater.

The deviation shall meet the limits shown in the table below.

Channel Spacing (kHz)	Relative Standard Deviation (RSD) (kHz)	92% of RS (kHz)	Tolerance (Hz)
12.5	2.5	2.3	+0/-50
20.0	4.0	3.68	+0/-80
25.0	5.0	4.6	+0/-100



NOTICE:

- The repeater will be factory-tuned in accordance to the above procedure and specification.
- Verification is performed outside of the Tuner application, i.e. in normal mode.

10.7.3

Tuning Procedure (with Tx Data or PL)

Procedure:

- 1 Connect the repeater's antenna port to the attenuation pad, if necessary, before connecting to the Communication Analyzer.
- 2 Turn on the repeater using an AC or DC source.
- 3 Click the "Read" button on the Tuner application to read the repeater's softpot values.
- 4 Select "Modulation Limit" under the Tx menu in the tree view.
- 5 Enter the tuning frequency into the Communication Analyzer (the value displayed by the Tuner application).
- 6 Click the "PTT Toggle" button within the Tuner environment to key up the repeater.
- 7 Apply a 1 kHz signal at 1.2Vrms to Pin 22 of the J7 backplane connector.
 - Signal ground is Pin 9 of the J7 backplane connector.
 - If the manufacturer of the third party controller specifies that the Tx Audio is not to be pre-emphasized, use Pin 1 instead of Pin 22.
- 8 Adjust the Modulation Limit softpot to a value that limits the maximum deviation to "X"% RSD, where "X" is equal to "92% RSD" minus "Tx Data's % RSD".

E.g. If Tx Data deviation is equal to 17%,

$X = 92\% - 17\% = 75\%$ as the maximum deviation limit.

Figure 48: Example of maximum deviation limit calculation

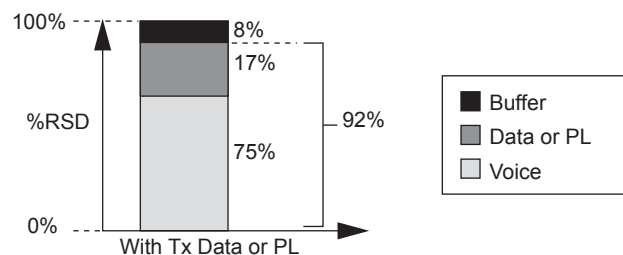

- 9 Click the "PTT Toggle" button within the Tuner environment to de-key the repeater.
- 10 Click "Write" to save the newly tuned softpot value into the repeater's codeplug.

11 Alignment is complete.



NOTICE:

- See [Figure 10: Audio Block Diagram on page 52](#) for details regarding the audio and data flow.
- Set the modulation limit to 92% to compensate for any additional deviation incurred by the transmitter VCOs over temperature.
- The Tuner application always aligns the Modulation Limit parameter in a 12.5 kHz channel spacing regardless of the CPS setting, so calculate the tuning % RSD accordingly. If the CPS is set for 25 kHz operation, the repeater will automatically scale the deviation by a factor of two when outside of the Tuner environment.

10.7.4

Verification (with Tx Data or PL)

See [Verification \(with no Tx Data and no PL\) on page 90](#) with the following exceptions:

- The same Tx data signal level determined (obtained from Step 8 in [Tuning Procedure \(with Tx Data or PL\) on page 91](#)), is applied to Pin 13 during the validation process.
- Pin 22 may be used instead of Pin 1, depending on the recommendation by the manufacturer of the third party controller.

10.8

Changing to Battery Charger Only Mode

This feature allows you to change operation mode from "Normal Mode" to "Battery Charger Only" mode.

Prerequisites: Power the repeater from an AC source and connect the system to a laptop with USB cable. Run the MOTOTRBO Tuner application.

Procedure:

- 1 Connect the battery to the repeater's DC connector.
- 2 Click the **Read** button.
- 3 Under the **Device Information** main menu, click the **Battery Charger Only Mode** button.

Testing procedure begins. When testing procedure ends, the display shows `All functions other than the battery charger will be disabled. Do you wish to continue?`

- 4 Do one of the following:
 - Click **Yes**. The display shows `The Unit is in battery charger only mode. Please remove power for 15 seconds to exit.`
 - Click **No** to return to the main menu.

Once remove battery, remove AC power and DC power for 15 seconds to restore full system functionality. The system only detects and charges another battery after restoring full system functionality.

Chapter 11

SLR 5000 Series Maintenance and Disassembly/Reassembly

11.1

Introduction

This chapter provides details about the following:

- Routine maintenance
- Preventive maintenance (inspection and cleaning)
- Safe handling of CMOS and LDMOS devices
- Disassembly and reassembly of the repeater
- Repair procedures and techniques.

11.2

Routine Maintenance



NOTICE: It is recommended that the repeater is cleaned with a soft dry cloth while in service.

The repeater and ancillary equipment have been designed with state-of-the-art technology and operate under software control, thus requiring minimal routine maintenance. Virtually all repeater operating parameters are monitored and self-corrected by the Modem and the firmware it runs, which makes adjustments and tuning virtually unnecessary.

Provided that the equipment is installed in an area which meets the specified environmental requirements, the only routine maintenance task required is the calibration of the repeater reference oscillator circuit.

11.3

Preventive Maintenance

Periodic visual inspection and cleaning is recommended.

11.3.1

Inspection

Check that the external surfaces of the repeater are clean, and that all external controls and connections are in order. It is not recommended to inspect the interior electronic circuitry.

11.3.2

Cleaning Procedures

The following procedures describe the recommended cleaning agents and the methods to be used when cleaning the external and internal surfaces of the repeater. External surfaces include the top cover and repeater enclosure.

Periodically clean smudges and grime from exterior enclosure. Use a soft, non-abrasive cloth moistened in a 0.5% solution of mild dishwashing detergent and water solution. Rinse the surface

using a second cloth moistened in clean water, and clean any dirt or debris from the fan grill and louvers on the front side.



NOTICE: Internal surfaces should be cleaned only when the repeater is disassembled for service or repair.

The only factory recommended liquid for cleaning the printed circuit boards and their components is isopropyl alcohol (100% by volume).

Cleaning Internal Circuit Boards and Components

Isopropyl alcohol (100%) may be applied with a stiff, non-metallic, short-bristled brush to dislodge embedded or caked materials located in hard-to-reach areas. The brush stroke should direct the dislodged material out and away from the inside of the repeater. Make sure that controls or tunable components are not soaked with alcohol. Do not use high-pressure air to hasten the drying process since this could cause the liquid to collect in unwanted places. Once the cleaning process is complete, use a soft, absorbent, lintless cloth to dry the area. Do not brush or apply any isopropyl alcohol to the top cover and repeater enclosure.



NOTICE: Always use a fresh supply of alcohol and a clean container to prevent contamination by dissolved material (from previous usage).

11.4

Safe Handling of CMOS and LDMOS Devices

Complementary metal-oxide semiconductor (CMOS) and laterally diffused metal-oxide semiconductor (LDMOS) devices are used in this family of stations, and are susceptible to damage by electrostatic or high voltage charges. Damage can be latent, resulting in failures occurring weeks or months later. Therefore, special precautions must be taken to prevent device damage during disassembly, troubleshooting, and repair.

Handling precautions are mandatory for CMOS/ LDMOS circuits and are especially important in low humidity conditions.

DO NOT attempt to disassemble the repeater without first referring to the following CAUTION statement.



CAUTION: This repeater contains static-sensitive devices. Do not open the repeater unless you are properly grounded. Take the following precautions when working on this unit:

- Store and transport all CMOS/ LDMOS devices in conductive material so that all exposed leads are shorted together. Do not insert CMOS/LDMOS devices into conventional plastic “snow” trays used for storage and transportation of other semiconductor devices.
- Ground the working surface of the service bench to protect the CMOS/LDMOS device. We recommend using the Motorola Solutions Static Protection Assembly (part number 0180386A82), which includes a wrist strap, two ground cords, a table mat, and a floor mat, ESD shoes and an ESD chair.
- Wear a conductive wrist strap in series with a 100k resistor to ground. (Replacement wrist straps that connect to the bench top covering are Motorola Solutions part number 4280385A59).
- Do not wear nylon clothing while handling CMOS /LDMOS devices.
- Do not insert or remove CMOS/ LDMOS devices with power applied. Check all power supplies used for testing CMOS/LDMOS devices to be certain that there are no voltage transients present.
- When straightening CMOS/ LDMOS pins, provide ground straps for the apparatus used.
- When soldering, use a grounded soldering iron.
- If at all possible, handle CMOS/ LDMOS devices by the package and not by the leads. Prior to touching the unit, touch an electrical ground to remove any static charge that you may have accumulated. The package and substrate may be electrically common. If so, the reaction of a discharge to the case would cause the same damage as touching the leads.

11.5

Disassembly

11.5.1

Disassembly – General

Station modules suspected of being faulty must be replaced with known good modules to restore the repeater to proper operation. The following are typical procedures to remove each of the repeater modules.

Procedure:

- 1 Power cord (and battery backup power, if used) and all external cables must be disconnected before opening up repeater. Label each removed cable as required to ensure it is properly reconnected.
- 2 Take the proper grounding precautions as stated in [Safe Handling of CMOS and LDMOS Devices on page 94](#).
- 3 When disassembling repeater, retain all screws for reuse.

The following tools are required for disassembling and reassembling the repeater:

- Torque Drivers (T10, T20 and T30). See [Torque Charts on page 113](#) for the different size fasteners of screw torques.
- Hex Nut Drivers (16 mm, ¾ inch [19 mm])
- Needle Nose Pliers (optional)
- Torque Gauge capable of measuring torque up to 20 in-lb (2.3 N-m) within +/- 1 in-lb (0.1 N-m)

If a unit requires more complete testing or service than is customarily performed at the basic level, send the repeater or FRU to a Motorola Solutions Service Center.

The following disassembly procedures should be performed only if necessary.

11.5.2

Disassembly – Detailed

11.5.2.1

Protective Cover Disassembly

Procedure:

- 1 Remove the six screws on the Bottom Cover with a T10 Torx driver.
- 2 Detach the Bottom Cover.
- 3 Remove the six screws on the Top Cover with a T10 Torx driver.
- 4 Detach the Top Cover.

11.5.2.2

Front Housing Disassembly

Procedure:

- 1 Remove the three screws securing the Front Housing to the repeater chassis with a T10 Torx driver.
- 2 Slightly lift the Repeater and rock the Front Housing away from the chassis.

Figure 49: Removing Front Housing from Repeater

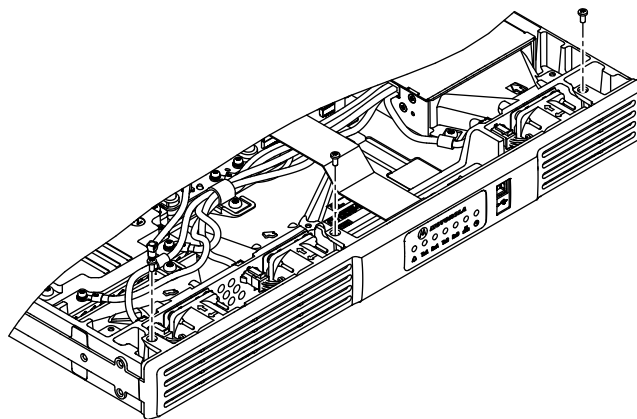

11.5.2.3

Cable Disassembly

Prerequisites:



NOTICE: When disengaging flexible cables, pull parallel to the insertion direction of the cable to avoid damaging the cables.

Procedure:

- 1 Disengage cable connecting Modem to Chassis ID module.



CAUTION: DO NOT attempt to remove the Chassis ID module as removing it will void the warranty as well as disabling any purchased software features. Keep the Chassis ID module installed throughout disassembly.

- 2 Remove the flex cables connecting the Modem to the Power Amplifier Module and Front Panel.
- 3 Remove the coaxial cable connecting the Modem to the Power Amplifier Module.
- 4 Gently press the locking clip and pull the “C5” connector from the Modem.
- 5 Remove the screws from the three cable clamps securing the cables from the power supply to the fans and modules with a T20 Torx driver and remove the cable clamps from repeater.
- 6 Remove the two DC power screws from the Power Amplifier Module with a T10 Torx driver.
- 7 Remove the two DC power screws from the Modem with a T10 Torx driver.
- 8 Disengage the three connectors from the Power Supply to the three mounted fans with needle nose pliers or fingers.

Figure 50: Removing Cables

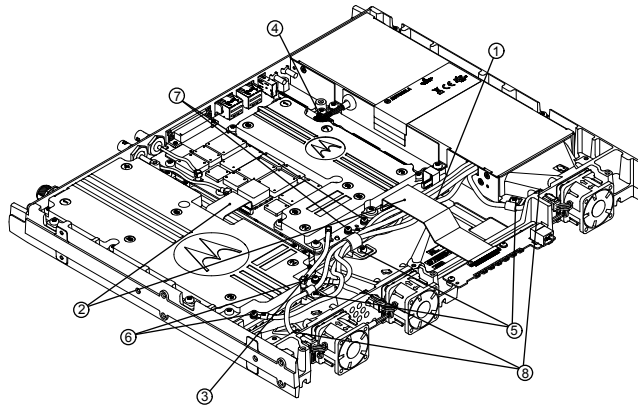

11.5.2.4

Fan Disassembly

Procedure:

- 1 Press the tab below the fan module until it disengages. See [Figure 51: Removing Fan on page 98](#) for location of tab.
- 2 Rock the fan module up and away from the frame and remove.
- 3 Repeat the steps above for the remaining two fan modules.

Figure 51: Removing Fan

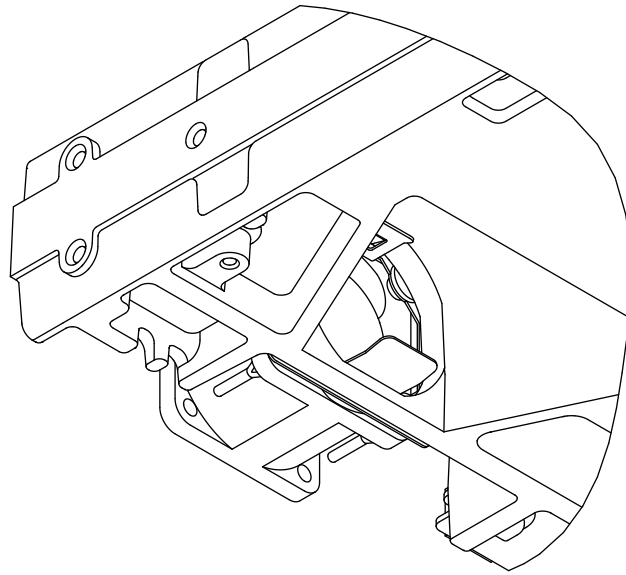

11.5.2.5

Front Panel Disassembly

Procedure:

- 1 Using a T10 Torx driver, remove the three screws securing the front panel to the repeater chassis.
- 2 Remove the Front Panel PCB from the repeater.

Figure 52: Removing Front Panel

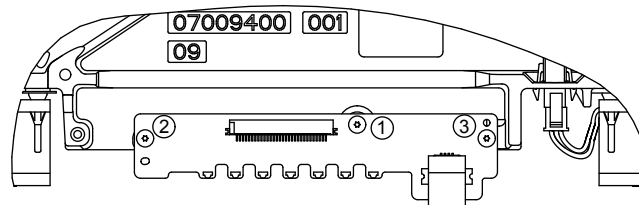

11.5.2.6

Power Supply Removal

Prerequisites:



NOTICE: Ensure all connections from Power Supply to various parts of the repeater have been detached.

Procedure:

- 1 Remove the four screws securing the Power Supply Module to the repeater chassis with a T20 Torx driver.

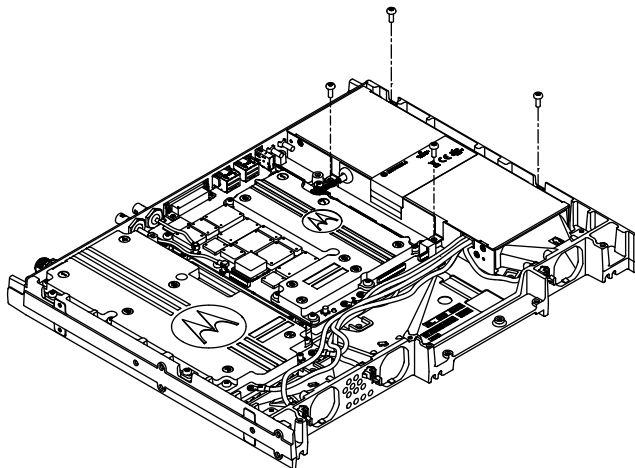
Figure 53: Removing Power Supply Module from Repeater

- 2 Remove the Power Supply Module from the repeater.

11.5.2.7

Modem Removal

Prerequisites:



NOTICE: Ensure all connections from Power Supply to various parts of the repeater have been detached.

Procedure:

- 1 Detach the two coaxial cables connecting the RX Input and Reference (REF) Input connectors to the Modem.
- 2 Remove the four screws holding the Modem to the repeater chassis with a T20 Torx driver.

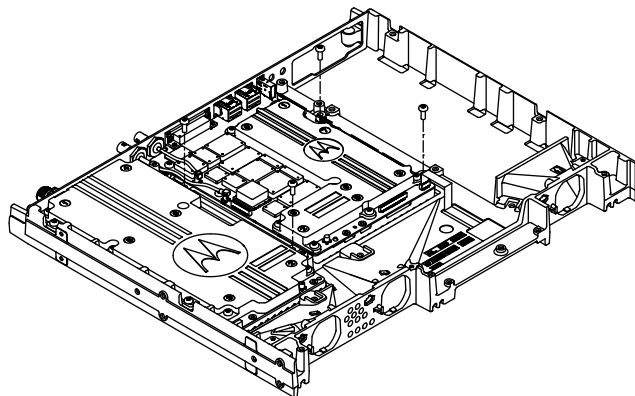
Figure 54: Removing Modem

- 3 Remove the Modem from the repeater.

11.5.2.8

Power Amplifier Module Removal

Prerequisites:



NOTICE: Ensure all connections from Power Supply to various parts of the repeater have been detached.

Procedure:

- 1 Remove the nut securing the N-Type connector to the back panel on the Power Amplifier with a $\frac{3}{4}$ inch (19 mm) hex nut driver.
- 2 Remove the accompanying lock washer.
- 3 Remove the four screws securing the Power Amplifier Module to the Repeater chassis with a T20 Torx driver.

Figure 55: Removing Power Amplifier Module

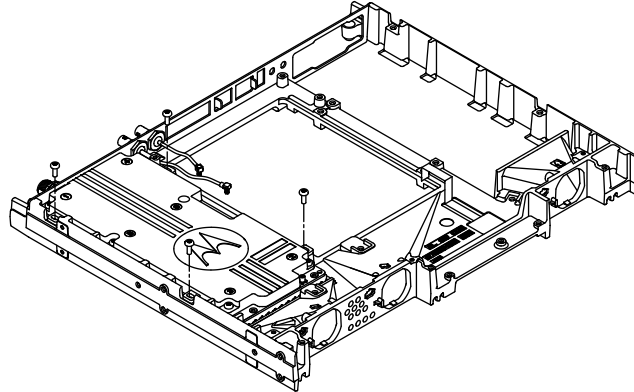

- 4 Remove the Power Amplifier Module from the Repeater.

11.5.2.9

Back Panel Removal

Procedure:

- 1 Remove the two nuts securing the RX and Reference (REF) BNC cables to the back panel with a 16 mm hex nut driver.
- 2 Remove the two corresponding lock washers.
- 3 Remove the two cables.

Figure 56: Removing Rx and REF BNC Cables

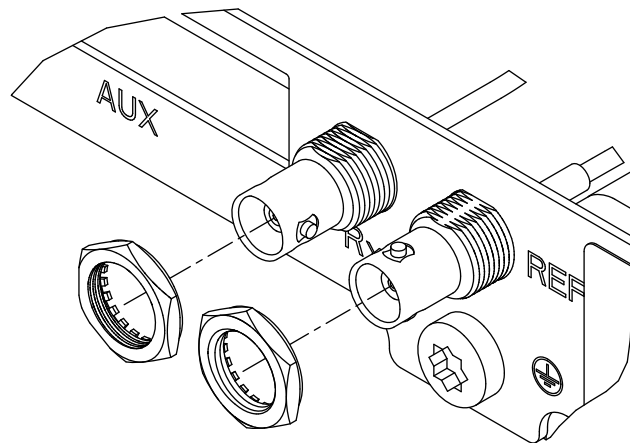

- 4 Remove the ground screw located below the REF connector with a T30 Torx driver.

Figure 57: Removing Ground Screw

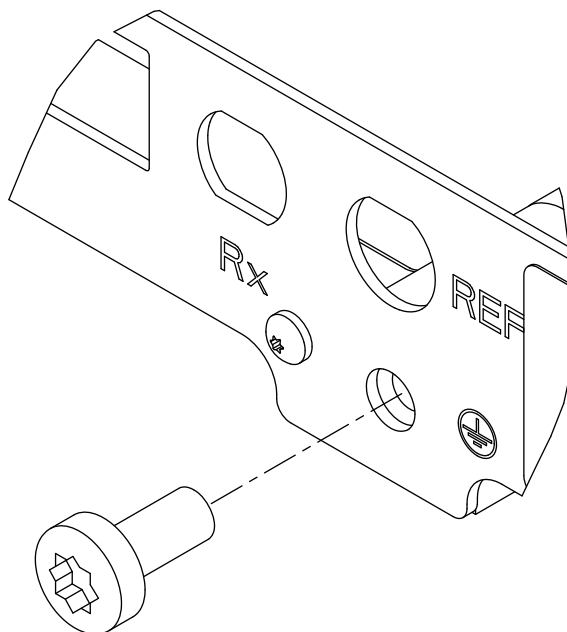

- 5 Remove the five screws securing the back panel to the repeater chassis with a T10 Torx driver.
- 6 Remove the back panel from the repeater.
- 7 Remove the two rubber plugs from the back panel.

11.6

Assembly and Reassembly

11.6.1

Assembly – Detailed

11.6.1.1

Back Panel Installation

Procedure:

- 1 Using a T10 Torx driver, install five M3 x 0.5 x 6 mm screws (PN: 0310907A18) to 10 in-lb (1.1 N-m). See [Figure 58: Installing M3 Screws on page 102](#).

Figure 58: Installing M3 Screws

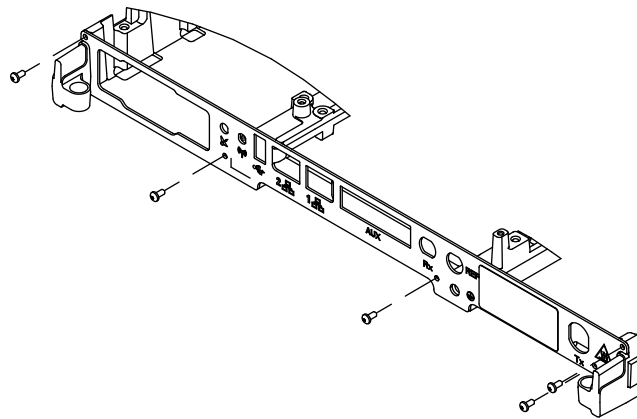

- 2 Using a T30 Torx driver, install a M6 x1x13 mm screw with captivated external tooth (PN: 00310909C91) to 20 in-lb (2.3 N-m).

Figure 59: Installing M6 Screw

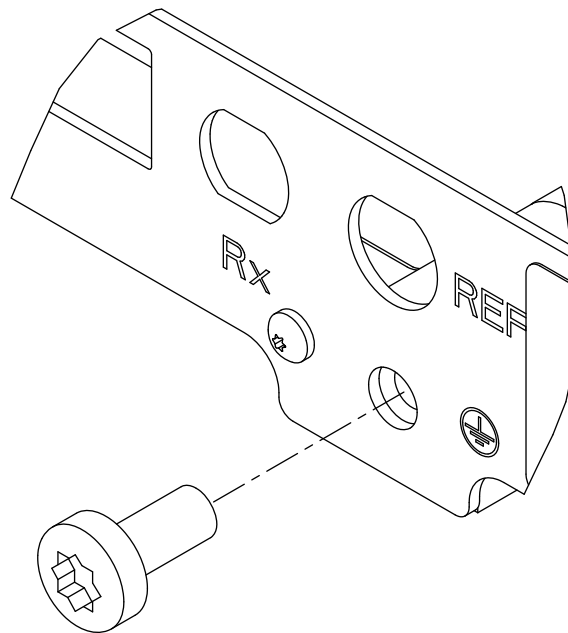

11.6.1.2

Input Cable Installation

Procedure:

- 1 Insert the RX (PN: 30012083001) and Reference (PN: CB000024A01) cables into corresponding holes in back panel.

Figure 60: Installing Rx and Reference Cables

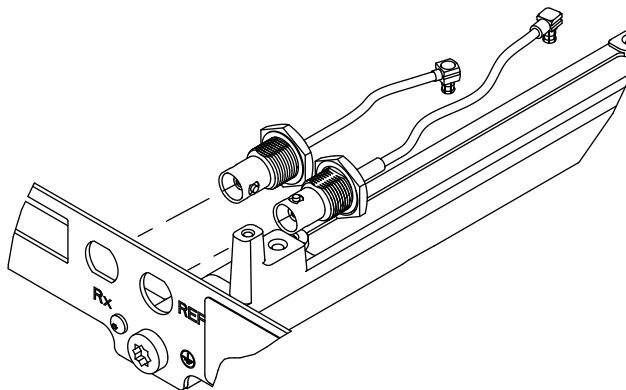

- 2 Assemble the corresponding lock washers onto the connectors. Using a 16 mm hex nut driver, tighten the 16 mm hex nuts to 15 in-lb (1.7 N-m) on both connectors.

Figure 61: Assembling Lock Washers onto Connectors

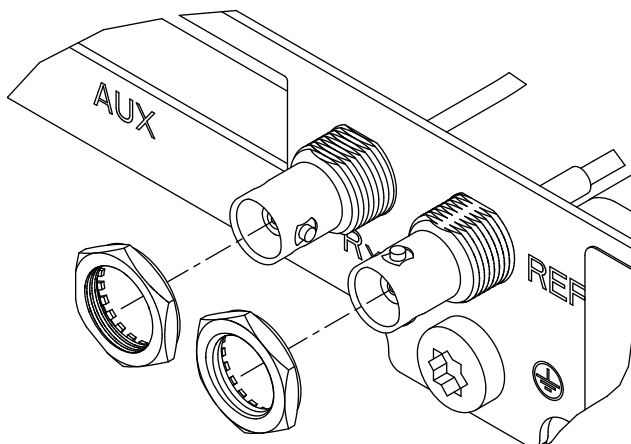

- 3 Insert two rubber plugs (PN 3287533V01) into the corresponding holes shown in [Figure 62: Installing WLAN and GNSS Rubber Plugs on page 103](#).

Figure 62: Installing WLAN and GNSS Rubber Plugs

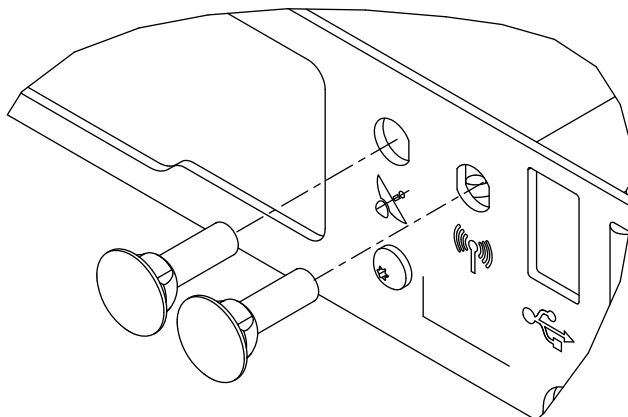

11.6.1.3

Power Amplifier Module Installation

Procedure:

- 1 Insert the TX connector into the back panel.
- 2 Slide the Power Amplifier Module into the repeater chassis until it rests against the back panel.

Figure 63: Installing Power Amplifier Module into Repeater

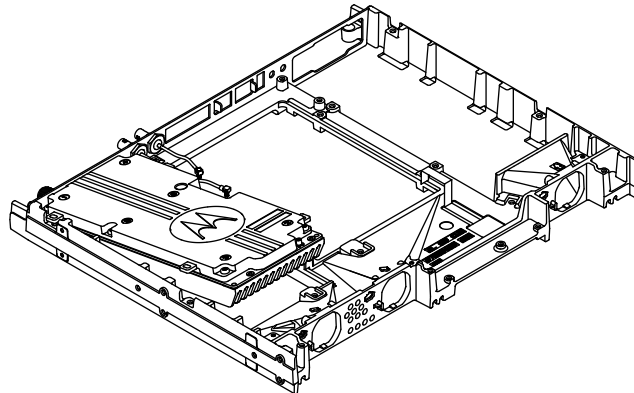

- 3 Lightly torque the four M4 x 0.7 x 10 mm screws (PN: 0310909A61) shown in [Figure 64: Securing Power Amplifier Module to Repeater Chassis on page 104](#) with a T20 Torx driver so the screws are very lightly installed. Do not tighten down beyond initial seating.
- 4 Assemble the lock washer (PN: 04009303001) and ¼ inch (19 mm) hex nut (PN: 02009277001) onto the TX connector of the Power Amplifier Module. Tighten the nut to 20 in-lb (2.3 N-m) with a ¾ inch (19 mm) hex nut driver.
- 5 Tighten the four M4 x 0.7 x 10 mm screws (PN: 0310909A61) to 15 in-lb (1.7 N-m) with a T20 Torx driver to secure the Power Amplifier Module to the repeater chassis.

Figure 64: Securing Power Amplifier Module to Repeater Chassis

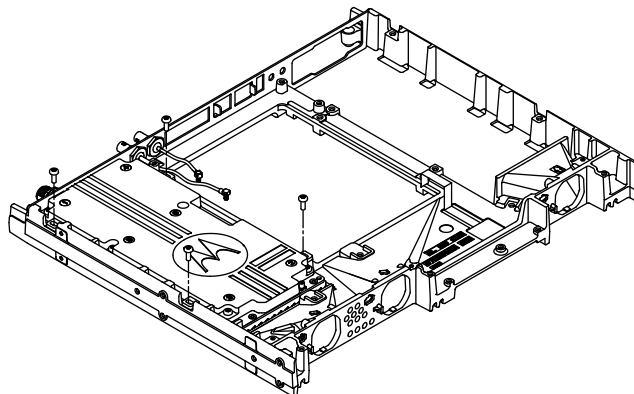

11.6.1.4

Modem Installation

Procedure:

- 1 Lift the RX and Reference (REF) cables and slide the Modem all the way to the back panel. Make sure the mounting ears on the Modem line up with the screw holes on the repeater chassis.

- 2 Tighten the four M4 x 0.7 x 10 mm screws (PN: 0310909A61) to 15 in-lb (1.7 N-m) using a T20 Torx driver to secure the Modem to the repeater chassis.

Figure 65: Securing Modem to Repeater Frame

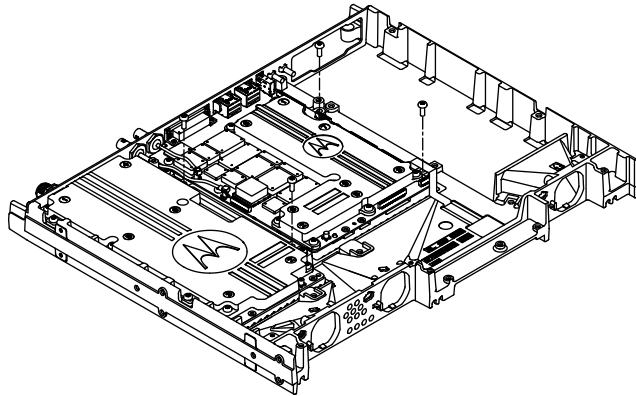

- 3 Secure the RX and REF cable connectors to the Modem.

Figure 66: Securing Rx and Reference Cable Connectors

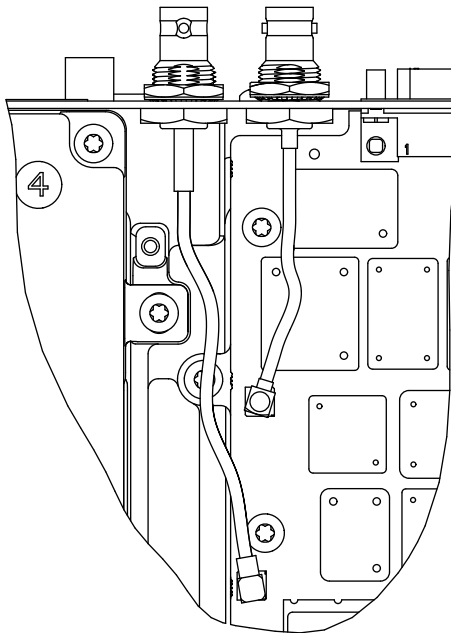

- 4 If replacing Modem FRU from Service Kit in [Service Parts on page 130](#), remove label PN LB000528A01 from kit package and place onto product label on back of repeater within the hash marks shown in [Figure 67: Modem FRU Product Label on page 106](#).

Figure 67: Modem FRU Product Label



11.6.1.5

Power Supply Installation

Procedure:

- 1 Place the Power Supply Module into the repeater chassis until the back of the power supply rests against back panel.

Figure 68: Installing Power Supply Module

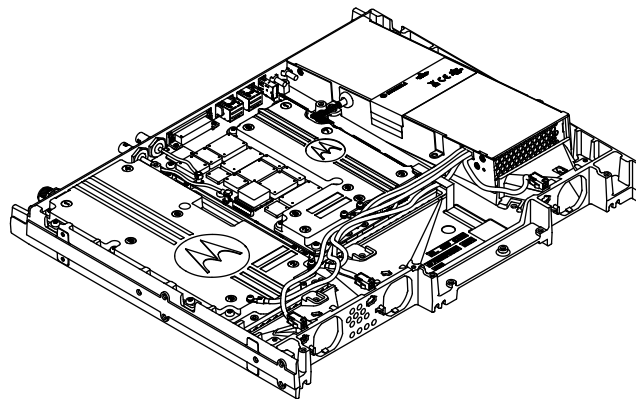

- 2 Take the Chassis ID Module (PN: 84009669001) and insert chassis ID cable end into the 8 pin connector on the Modem. Route Chassis ID Module cable underneath power supply cables.
- 3 Tighten the four M4 x 0.7 x 10 mm screws (PN: 0310909A61) to 15 in-lb (1.7 N-m) using a T20 Torx driver to secure the Power Supply Module to the repeater chassis.

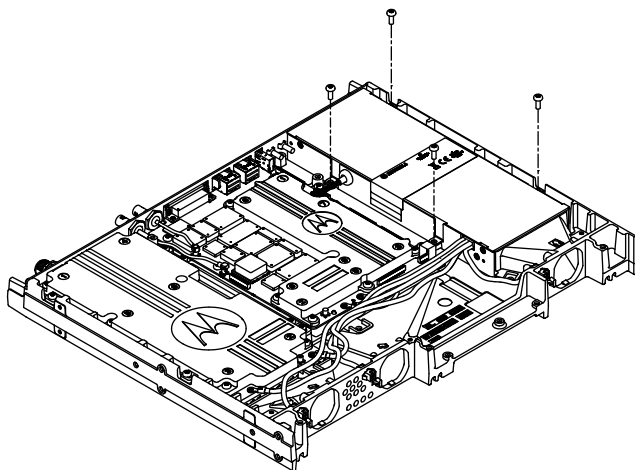
Figure 69: Installing M4 Screws

- 4 Snap the fan jumper cables into the chassis for the Power Supply, Modem, and Power Amplifier fans.

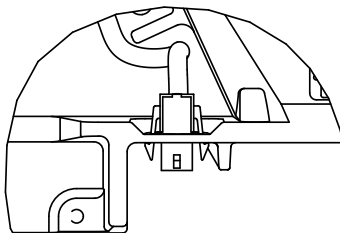
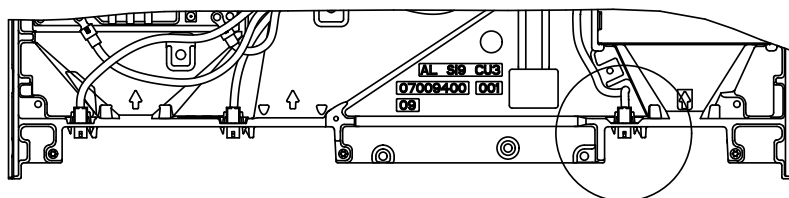
Figure 70: Snapping Fan Cable

11.6.1.6

Fan Installation

Procedure:

- 1 Orient the fan module so that the cables are out at the lower left. See [Figure 71: Installing Fan on page 108](#).
- 2 Rest the bottom tab of the mounting bracket onto the main frame opening with proper orientation.
- 3 Push the fan assembly towards the main frame until both tabs are fully snapped and engaged. Two audible snaps should be heard.
- 4 Repeat the steps above for the remaining two fans.

Figure 71: Installing Fan

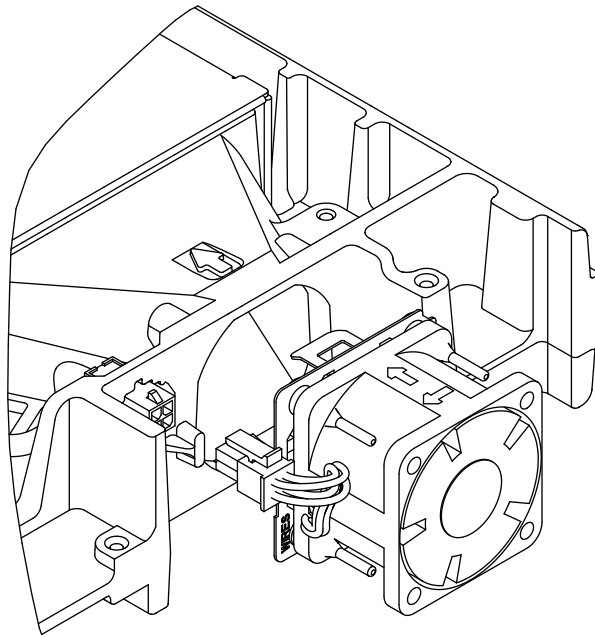

 **NOTICE:** For each of the fans, look inside the fan shroud to ensure both the top and bottom fan mounting bracket tabs are fully engaged with the protrusions (teeth) of the base frame.

- 5 Connect the three fan cables to their corresponding jumper cables.

11.6.1.7

Front Panel Installation

Procedure:

- 1 Place the Front Panel (Kit Number: PMLN6490A) onto the corresponding bosses on the repeater frame.
- 2 Install the three M3 x 0.5 x 6 mm screws (PN: 0310907A18) to 10 in-lb (1.1 N-m) in the order shown in [Figure 72: Installing Front Panel on page 108](#) using a T10 Torx driver.

Figure 72: Installing Front Panel

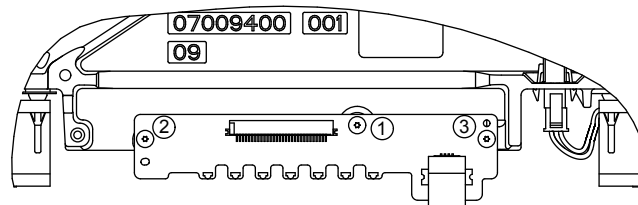

11.6.1.8

Cable Installation

Prerequisites:



CAUTION: Do not over torque the power screws as damage may occur.

Procedure:

- 1 Install the two power screws from the Power Supply Module into the PA board to 6.5 in-lb (0.7 N-m) using a T10 Torx driver.
- 2 Install the two power screws from the Power Supply Module into the Modem board to 6.5 in-lb (0.7 N-m) using a T10 Torx driver.



CAUTION: Ensure that correct polarity of the modem power supply module is observed otherwise damage may occur.

Figure 73: Installing Power Screws

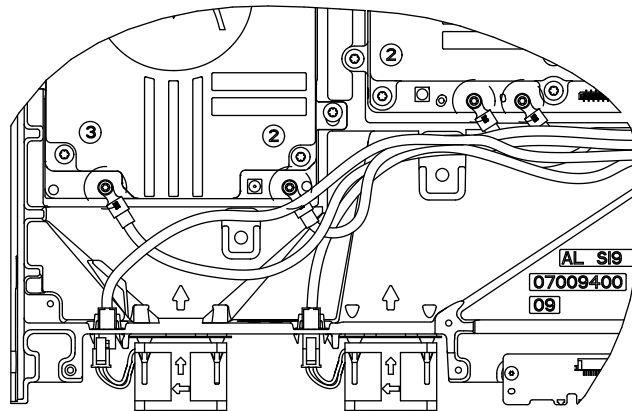

- 3 Secure the “C3” cable from the Power Supply Module to the chassis in the pocket near the Power Supply Module using a cable clamp (PN: 42009306001) and a M4 x 0.7 x 10 mm screw (PN: 0310909A61) torque to 15 in-lb (1.7 N-m) using a T20 Torx driver.

Figure 74: Securing Cables

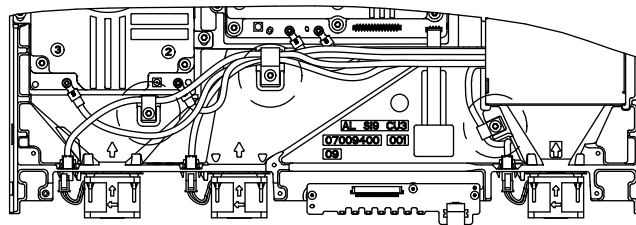

- 4 Secure the “C2”, “C4” and “C6” cables from the Power Supply Module to the chassis near the Modem using a cable clamp (PN: 42009306002) and a M4 x 0.7 x 10 mm screw (PN: 0310909A61) torque to 15 in-lb (1.7 N-m) using a T20 Torx driver.
- 5 Secure the “C6” cable from the Power Supply Module to the chassis near the PA Module using a cable clamp (PN: 42009306001) and a M4 x 0.7 x 10 mm screw (PN: 0310909A61) torque to 15 in-lb (1.7 N-m) using a T20 Torx driver.
- 6 Secure the connector of the “C5” cable between the Power Supply Module and the Modem to the corresponding Modem Connector.
- 7 Assemble the coaxial cable (PN: 30012084001) to the connectors on the Modem and PA Module



NOTICE: When installing the flexible cables, directly insert the cable parallel to the connector to avoid damage to the connector. Do not assemble at angle.

- 8 Assemble the flex cable (PN: 30012085001) between the PA Module and the Modem. Install the PA Module side first.
- 9 Assemble the flex cable (PN: 84007002001) between the Modem and the Front Panel.

11.6.1.9

Front Housing Installation

Procedure:

- 1 Line up the tabs on the Front Housing (PN: HN000198A01) to the pins on the repeater chassis and engage them. With all three tabs engaged, rotate the Front Housing into place.

Figure 75: Securing Front Housing

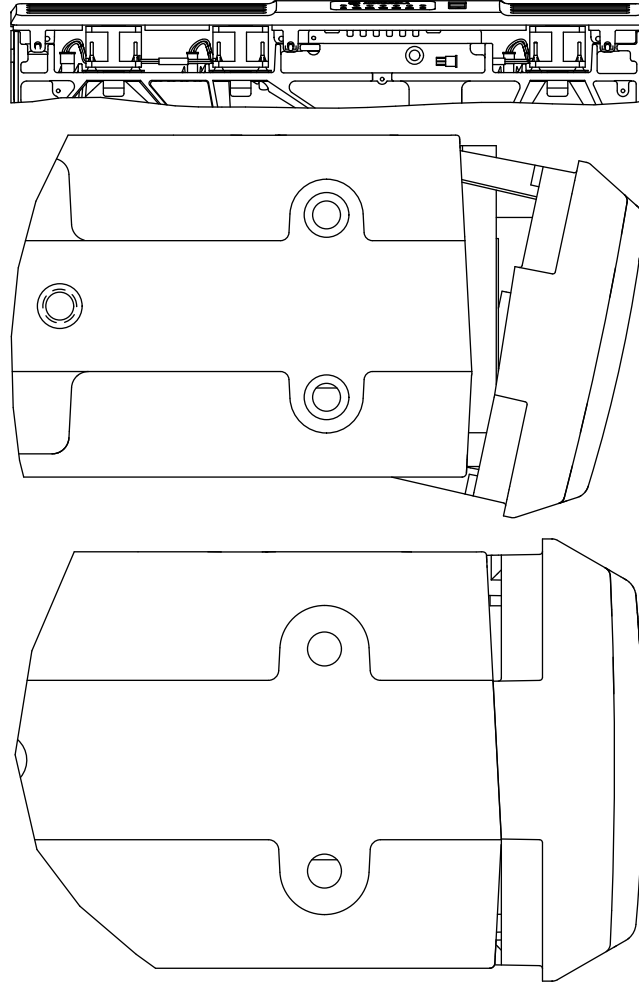

- 2 Install the three M3 x 0.5 x 6 mm screws (PN: 0310907D02) to 10 in-lb (1.1 N-m) using a T10 Torx driver.

Figure 76: Installing M3 Screws

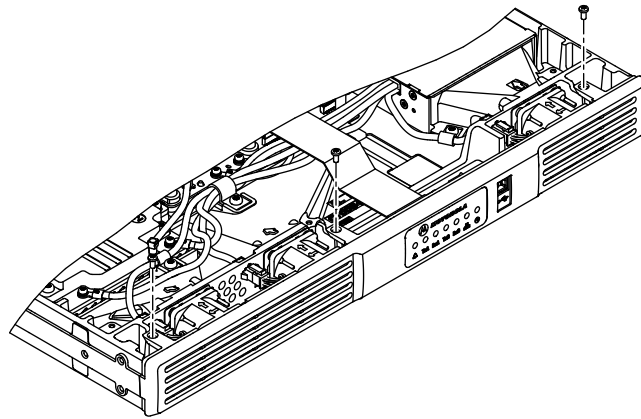

11.6.1.10

Protective Cover Installation

Procedure:

Install the six M3 x 0.5 x 6 mm screws each (PN: 0310907D02) to 12 in-lb (1.3 N-m) using a T10 Torx driver to secure the bottom and top cover (PN: 07009402001) to the repeater chassis.

11.7

Exploded Mechanical View

Figure 77: SLR 5000 Series Assembly Exploded View

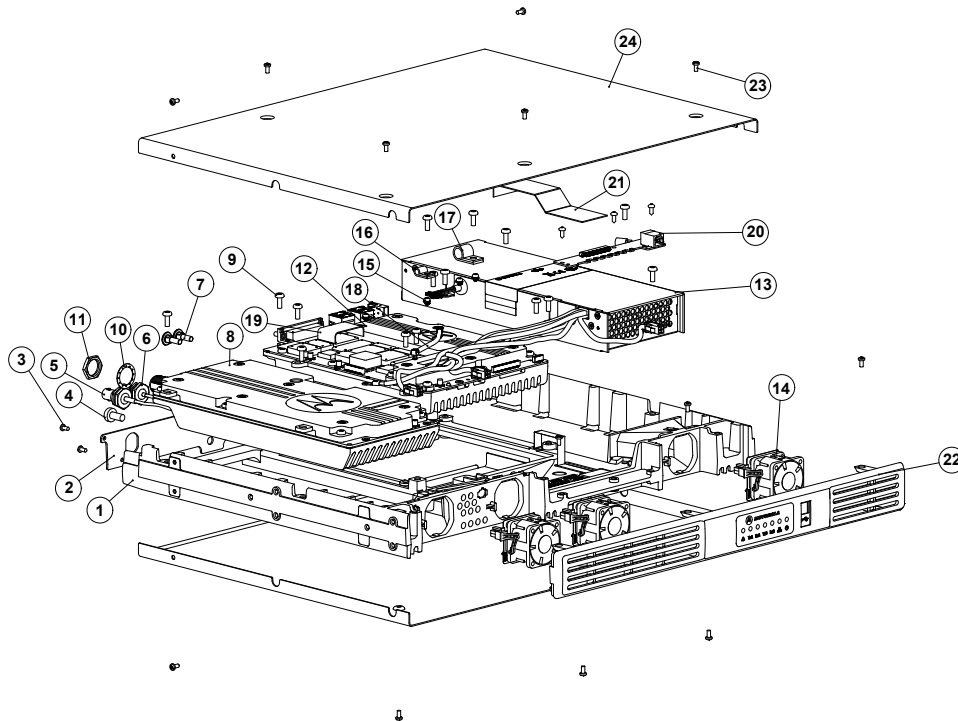

11.8

Parts List

Table 37: SLR 5000 Series Exploded View Parts List

Item No.	Description	Part Number	Quantity
1	Chassis	See Service Parts on page 130 .	1
2	Back Plate	64009331001	1
3	M3 Screw	0310907A18	8
4	M6 Screw, Ground	0310909C91	1
5	RF Cable, Rx	30012083001	1
6	RF Cable, Reference	CB000024A01	1
7	Rubber Plugs	3287533V01	2
8	PA, FRU	See Service Parts on page 130 .	1
9	M4 Screw	0310909A61	15
10	Locking Washer	04009303001	1
11	Locking Nut	02009277001	1
12	Modem FRU	See Service Parts on page 130 .	1
13	PSU FRU	See Service Parts on page 130 .	1
14	Fan Assembly	See Service Parts on page 130 .	3
15	M3 Screw, Insert	03009387001	4
16	Cable Clamp, Small	42009306001	2
17	Cable Clamp, Large	42009306002	1
18	RF Cable, Tx	30012084001	1
19	PA/ Modem FFC	30012085001	1
20	Front Panel Assembly	See Service Parts on page 130 .	1
21	Front Panel FPC	84007002001	1
22	Front Housing Assembly	HN000198A01	1
23	M3 Screw, Black	0310907D02	15
24	Cover, Top/ Bottom	07009402001	2

11.9

Torque Charts

[Table 38: Torque Specifications for Nuts and Screws on page 113](#) lists the various screws by description and torque values in different units of measure. Torque all screws to the recommended value when assembling the repeater.

Table 38: Torque Specifications for Nuts and Screws

Driver Type	Torque		
	N-m (± 0.1)	in-lb (± 1)	kg-cm (± 1.2)
Torx T10 (Front Housing/Panel)	1.1	10	11.5
Torx T10 (Protective Covers)	1.3	12	13.8
Torx T10 (Power Inserts)	0.7	6.5	7.5
Torx T20	1.7	15	17.3
Torx T30	2.3	20	23.0
$\frac{3}{4}$ Inch (19 mm) Hex Nut Driver	2.3	20	23.0
16 mm Hex Nut Driver	1.7	15	17.3

This page intentionally left blank.

Chapter 12

SLR 5000 Series Installation

12.1

Pre-Installation Considerations

Proper installation ensures the best possible performance and reliability of the repeater.

Pre-installation planning is required. This includes considering the mounting location of the equipment in relation to input power, antennas, and system interfaces. Also to be considered are site environment conditions, the particular mounting method (several available), and required tools and equipment.

It is highly recommended that to read the following before installing this type of equipment for the first time:

- this entire installation section before beginning the actual installation, and
- the Motorola Solutions Quality Standard Fixed Network Equipment Installation manual, R56 (which can be obtained by ordering CDROM 9880384V83), specifically refer to the information on ground connection for lightning protection.

12.1.1

Installation Overview

The following information is an overview for installing the repeater and ancillary equipment.

Step-by-step procedures for each of the major installation tasks are then provided beginning in [Mechanical Installation on page 122](#).

- Plan the installation, paying particular attention to environmental conditions at the site, ventilation requirements, and grounding and lightning protection.
- Unpack and inspect the equipment.
- Mechanically install the equipment at the site.
- Make necessary electrical and cabling connections, including the following:
 - AC input cabling
 - Coaxial cables to transmit and receive antennas
 - System cables
- Perform a post-installation function checkout test of the equipment to verify proper installation. Proceed to the Optimization procedures to customize the repeater parameters per customer specifications (e.g., operating frequency, PL, codes, etc.)

12.1.2

Site Environmental Conditions



CAUTION: If the repeater is to be installed in an environment which is unusually dusty or dirty (and so does not meet the air quality requirements), the air used to cool the repeater modules must be treated using appropriate filtering devices. Dust or dirt accumulating on the internal circuit boards and modules is not easily removed, and can cause such malfunctions as overheating and intermittent electrical connections.

The repeater may be installed in a suitable, restricted access, indoor enclosure in any location suitable for electronic communications equipment, provided that the environmental conditions do not exceed the equipment specifications for temperature, humidity and air quality.

These are:

- Operating Temperature Range
-30 °C (-22 °F) to +60 °C (+140 °F)

This is the temperature measured in close proximity to the repeater. For example, if the repeater is mounted in a cabinet, the temperature within the cabinet is measured.

- Humidity
Repeater to be kept at or below RH of 95%, non-condensing at 50 °C (122 °F).

- Air Quality
For equipment operating in an environmentally controlled environment with the repeater(s) rack mounted, the airborne particulates level must not exceed 25 µg/m³.

For equipment operating in an area which is not environmentally controlled (repeater(s) cabinet mounted), the airborne particulates level must not exceed 90 µg/m³

12.1.3

Equipment Ventilation

The repeaters are equipped with cooling fans that are used to provide forced convection cooling. When planning the installation, observe the following ventilation guidelines:

12.1.3.1

Mounting the SLR 5000 Series Repeater in a Cabinet

- Cabinets must be equipped with ventilation slots or openings in the front (for air entry) and back or side panels (for air to exit). If several repeaters are installed in a single cabinet, be sure ventilation openings surround each repeater to allow for adequate cooling.
- All cabinets must have at least 15 cm (6 in) of open space between the air vents and any wall or other cabinets. This allows adequate air flow.
- When multiple cabinets (each equipped with several repeaters) are installed in an enclosed area, make sure the temperature within each cabinet does not exceed the recommended/ maximum operating temperature of +60 °C (+140 °F). It may be necessary to have air-conditioning or other climate-control equipment installed to satisfy the environmental requirements.



CAUTION:

- The mounting of only ONE REPEATER PER CABINET is recommended. More than one repeater per cabinet will result in degradation of thermal specifications at high ambient temperatures.
- Appropriate precautions should be taken to ensure that repeater ambient temperature does not exceed +60 °C (+140 °F).
- If multiple repeaters are required, AND THERMAL SPECIFICATION DEGRADATION IS ACCEPTABLE, the following is recommended when no cabinet fans are used. Up to three repeaters can be mounted in a 76.2 cm (30 in) or larger cabinet with two rack units of spacing between each repeater. This will result in thermal specification performance of -30 °C (-22 °F) to +40 °C (+104 °F).

12.1.3.2

Mounting the SLR 5000 Series Repeater in a Rack

Multiple SLR 5000 series repeaters can be mounted in an open rack without degradation of specification.

12.1.4

AC and DC Input Power Requirements

12.1.4.1

AC Input Power Requirements

The repeater is equipped with a switching power supply, and this assembly operates from 100 – 240 VAC at 47 – 63 Hz AC input power. A standard 3-prong line cord is supplied to connect the power supply to the AC source.

It is recommended that a standard 3-wire grounded electrical outlet be used as the AC source.



CAUTION: The AC socket outlet must be installed near the equipment and must be easily accessible.

The outlet must be connected to an AC source capable of supplying a maximum of 500 VA. For a nominal 110/ 120 VAC input, the AC source must supply 5 A (minimum). Per R56, the minimum ampacity of the circuit (and protective breaker) feeding the repeater should be no less than 15A. For a nominal 220/ 240 VAC input, the ampacity requirements can be halved.

12.1.4.2

DC Input Power Requirements

The DC source operates from 11 VDC to 14.4 VDC (17 A max). This DC source must be located in the same building as the repeater, and it must meet the requirements of a SELV circuit. The appropriate DC disconnects and current limiting devices must be chosen and implemented per R56.

12.1.4.3

Ground Connection

The repeater is equipped with a ground screw located on the back panel of the repeater. [Figure 81: Back Panel Connector Names and Locations on page 124](#) shows the location of the grounding screw. Connect the ground screw to the site ground point. The size of the wire used for this connection must be 8 AWG minimum.



CAUTION: Refer to Motorola Solutions Quality Standards Fixed Network Equipment Installation Manual R56 (which can be obtained by ordering CDR0M 9880384V83), for complete information regarding lightning protection.



CAUTION: The repeater should only be connected to a battery supply that is in accordance with the applicable electrical codes for the end use country; for example, the National Electrical Code ANSI/ NFPA No. 70 in the U.S.

12.1.4.4

Battery Connection

Battery backup interface offers the capability of connecting to battery backup power in the event of an AC power line failure. The battery backup system is connected to the repeater through the DC inlet connector on the rear panel of the repeater. See [Figure 81: Back Panel Connector Names and Locations on page 124](#) for the location of the DC inlet connector.



CAUTION: The repeater should only be connected to a battery supply that is in accordance with the applicable electrical codes for the end use country; for example, the National Electrical Code ANSI/NFPA No. 70 in the U.S.

12.1.4.5

RF Antenna Connections

The transmit and receive antenna RF connections are made using two separate connectors. Coax cables from the receive and transmit antennas must be connected to their respective connectors. The position of these connectors is shown in [Figure 81: Back Panel Connector Names and Locations on page 124](#), and their respective connector types are noted in [Table 42: Connector Type and Primary Function on page 124](#).

12.1.4.6

System Cable Connections

System connections are made through the Aux and/or Ethernet connectors located on the back panel of the repeater. The positions of the Aux and Ethernet connectors are shown in [Figure 81: Back Panel Connector Names and Locations on page 124](#).

See [Auxiliary \(Aux\) on page 71](#) for a description of the signaling that is supported by the Aux connector.

12.1.5

Equipment Mounting Methods

Repeater may be mounted in a rack or cabinet. It may also be configured as a desk mount or wall mount unit.

Repeater can be mounted:

- In a floor-mount cabinet. Each floor-mount cabinet has front and rear vented doors and has the capacity to hold a minimum of a single repeater (see thermal limitations described under Equipment Ventilation), and required ancillary equipment. The larger cabinets provide additional room for supplementary peripheral equipment.
- In a rack. Open frame racks accept multiple repeaters and ancillary equipment; EIA 48.3 cm (19 inch) rack configuration.

12.1.5.1

Floor-Mounted Cabinet

The front, side and top views for all available floor-mount cabinets are shown in [Figure 78: Floor Mount Cabinet on page 119](#). See [Table 39: Cabinet Models on page 118](#) for the cabinet models and associated description.

Table 39: Cabinet Models

Model	Description
THN6700	12 in. (30.48 cm) indoor cabinet
THN6701	30 in. (76.2 cm) indoor cabinet
THN6702	46 in. (116.84 cm) indoor cabinet

Refer to [Equipment Ventilation on page 116](#) for recommended ventilation clearances. For improved access to the unit, tray slides are available as shown in [Table 40: Cabinet Slide on page 118](#).

Table 40: Cabinet Slide

Model	Description
THN6788	Slides Motorola Solutions Cabinet



CAUTION: Ensure that the cabinet is securely anchored to the floor, thereby avoiding possible equipment tipping and personal injury.

Figure 78: Floor Mount Cabinet

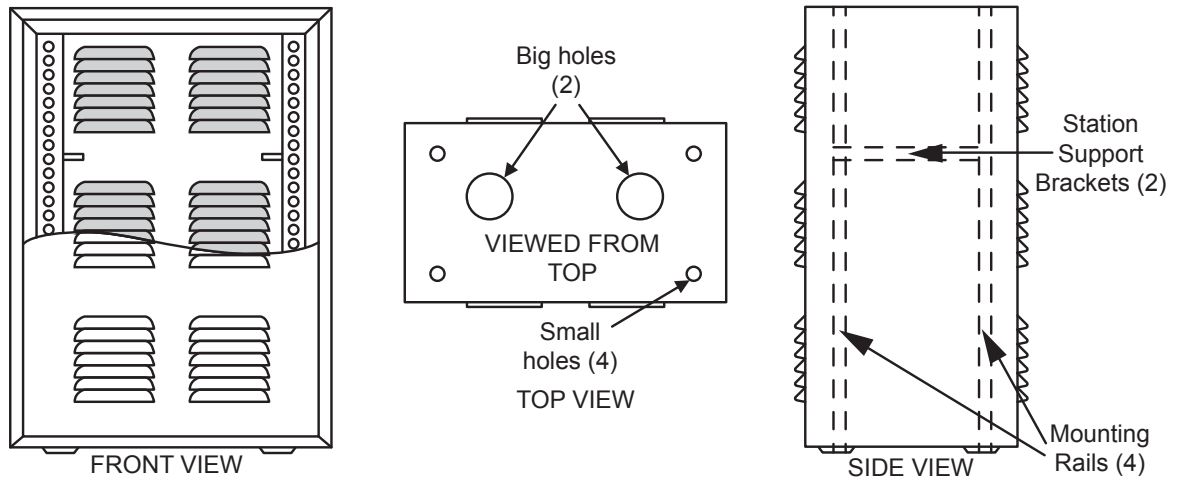

12.1.5.2

Modular Racks

See [Table 41: Rack Models on page 119](#) for the rack models and associated description.

Table 41: Rack Models

Model	Description
THN6752	30 in. (76.2 cm) Modular Rack (16 RK U)
THN6753	45 in. (114.3 cm) Modular Rack (24 RK U)
THN6754	52 in. (132.08 cm) Modular Rack (27 RK U)

The side, top and bottom views for all available modular racks are shown in [Figure 79: Modular Rack on page 120](#). The top and bottom plates are identical and all dimensions and clearances are common to all racks.

Recommended clearance front and rear is 91.44 cm (36 in) minimum for servicing access. Refer to [Equipment Ventilation on page 116](#) for recommended ventilation clearances.

FRU kit PMLN6826 (Rack Mount Hardware) is included with each rack model. This allows proper installation of the SLR 5000 series repeater within the racks center of gravity.

Figure 79: Modular Rack

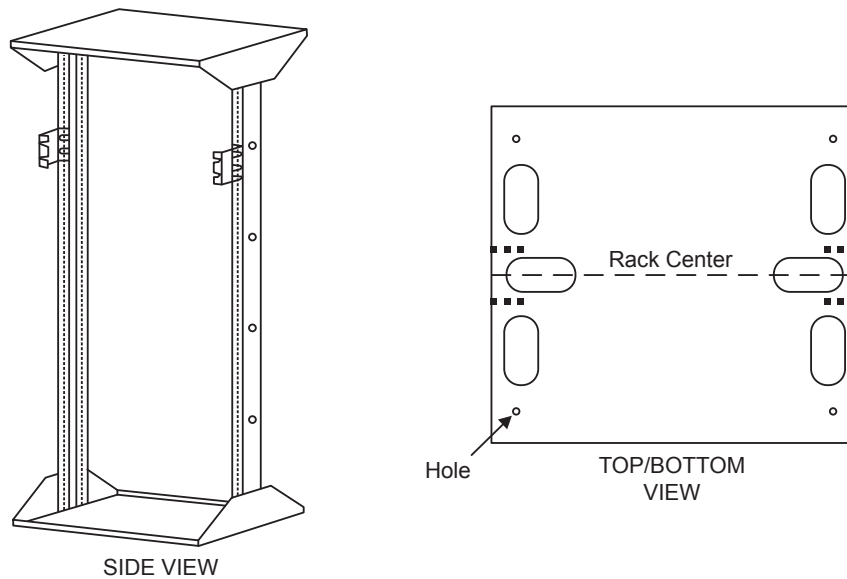

12.1.5.3

Desk Mount

The repeater can be set up for mounting onto a desk. See [Desk Mount on page 124](#) for installation details.

12.1.6

Site Grounding and Lightning Protection



CAUTION: Proper site grounding and lightning protection are vitally important considerations. Failure to provide proper lightning protection may result in permanent damage to the radio equipment.

One of the most important considerations when designing a communications site is the ground and lightning protection system. While proper grounding techniques and lightning protection are closely related, the general category of site grounding may be divided into the following sections.

12.1.6.1

Electrical Ground

Ground wires carrying electrical current from circuitry or equipment at the site is included in the category of electrical ground. Examples include the AC or DC electrical power used to source equipment located at the site, and wires or cables connected to alarms or sensors located at the site.

12.1.6.2

RF Ground

This type of ground is related to the bypassing of unwanted radio frequency energy to earth ground. An example of RF grounding is the use of shielding to prevent or at least minimize the leakage of unwanted RF energy from communications equipment and cables.

12.1.6.3

Lightning Ground

Providing adequate lightning protection is critical to a safe reliable communications site. RF transmission cables, and AC and DC power lines must all be protected to prevent lightning energy from entering the site.

Comprehensive coverage of site grounding techniques and lightning protection is not within the scope of this instruction manual, but there are several excellent industry sources for rules and guidelines on grounding and lightning protection at communications sites.



NOTICE: Motorola Solutions recommends the following reference source:
Motorola Solutions Quality Standards Fixed Network Equipment Installation Manual R56: (which can be obtained by ordering CDROM 9880384V83).

12.1.6.4

Equipment Grounding

The repeater is equipped with a ground screw located on the rear of the repeater power supply module. This screw is used to connect the repeater to the site grounding. All antenna cables, and AC and DC power cabling, should be properly grounded and lightning protected by following the rules and guidelines provided in the above reference. Failure to provide proper lightning protection may result in permanent damage to the repeater.

12.1.7

Recommended Tools and Equipment

In addition to the typical compliment of hand tools, the following tools and equipment are recommended for proper installation of the repeater equipment.

- Tarpaulin or plastic drop cloth or cover surrounding equipment while drilling concrete anchor holes (for installations where cabinet or rack is being anchored to concrete).
- Vacuum cleaner for removing concrete dust caused by drilling.

12.1.8

Equipment Unpacking and Inspection

12.1.8.1

Unpacking Equipment

Refer [Model Chart on page 43](#).

Remove repeater from cardboard box. Remove foam corners and remove repeater from antistatic bag. Keep all packing components for future shipping of repeater.

12.1.8.2

Initial Inspection

- After removing the repeater from the packaging, set on the surface for inspection. Top and bottom protective covers should be free of damage. Front housing should have no obvious scuffs or marks.
- Back Panel connectors should be free of damage. Connectors should not be bent with regard to the back panel. Threads on RF connectors should be free of debris and undamaged.
- Remove protective liner from lens on LED display.
- If any part of the equipment has been damaged in transit, immediately report the extent of the damage to the transportation company and to Motorola Solutions.

- When a repeater is delivered from Motorola Solutions, it arrives in suitable packing materials. If the unpacked equipment is damaged, return it to Motorola Solutions in its original packaging.



CAUTION: Equipment should be handled in its original packaging until it is delivered to its final destination. If the equipment is damaged while being moved without the original packaging, the warranty claim is not valid.

12.2

Mechanical Installation

12.2.1

Equipment Unpacking and Inspection

Remove repeater from cardboard box. Remove foam corners and remove repeater from antistatic bag.



NOTICE: Antistatic plastic bags and foam corners should be kept for future shipping/transporting of repeater.

Thoroughly inspect the equipment as soon as possible after delivery. If any part of the equipment has been damaged in transit, immediately report the extent of the damage to the transportation company and to Motorola Solutions.

When a repeater is delivered from Motorola Solutions, it arrives in suitable packing materials. If the unpacked equipment is damaged, return it to Motorola Solutions in its original packaging.



CAUTION: Equipment should be handled in its original packaging until it is delivered to its final destination. If the equipment is damaged while being moved without the original packaging, the warranty claim is not valid.

Improper handling of the repeater may cause personal injury or damage to the repeater.

12.2.2

Mounting Procedures

The repeaters can be mounted in the selected cabinet or rack, and may be installed by following the procedures below.

12.2.2.1

Transferring Equipment from Shipping Container to Rack or Cabinet

As mentioned under Equipment Unpacking and Inspection, a repeater can be shipped in a box. Upon delivery, the equipment must be removed from the container and transferred to a rack or cabinet.



NOTICE: Cabinets and racks must have mounting rails and hole spacing compatible with EIA Universal 48.3 cm (19 in.) specifications. Cabinets must provide adequate ventilation (as detailed under Equipment Ventilation) and must meet the following criteria:

41.3 cm (16.25 in.) deep

48.3 cm (19 in.) wide

13.4 cm (5.25 in.) high

Two mounting rails 5 cm (2 in.) from front of cabinet with front mounting holes

5.7 cm (2.25 in.) apart (center to center).

Contact Motorola Solutions Customer Support for specific questions regarding mounting equipment in customer-supplied cabinets.

12.2.2.2

Installing Racks

In a typical installation, the rack is bolted to a concrete floor to provide stability.

Prerequisites:

The following procedure describes the steps necessary to bolt the rack to a concrete floor. Be sure to check with local authorities to verify that the following procedure conforms to local building codes and regulations before permanently installing the rack.

Procedure:

- 1 Carefully align the rack at the desired anchoring location.
- 2 Use the rack mounting foot as a template and mark the location of the six 19 mm (3/4 in) diameter mounting holes. All six anchoring positions must be used.
- 3 Move the rack aside, drill holes in the concrete floor, and install the mounting anchors (RAM RD-56 anchors recommended) per instructions provided with the anchors. Make sure that none of the anchors comes in contact with the reinforcing wire mesh buried in the concrete; the rack must be electrically isolated from any other equipment or materials at the site.
- 4 Align the rack with the installed anchors and lightly secure the rack to the floor using the proper mounting hardware. Do not tighten the mounting hardware at this time.
- 5 Check the vertical plumb of the rack. Also check that the top is level. Use shims (flat washers or flat aluminum plates) as necessary under the rack mounting foot to achieve vertical plumb and horizontal level.
- 6 Tightly secure the rack to the floor anchors making sure that it remains vertically plumb and horizontally level.
- 7 Assemble the two mounting brackets to each side of the repeater either in the front or middle of the repeater depending on whether rack is made for front mount or mid-mount using three supplied screws for each bracket.
- 8 Hold repeater in the desired rack location. Line up mounting bracket holes with mounting locations on rack rail and assemble both brackets to the mounting rail on the rack using 10-32 screws.

**CAUTION:**

Cement dust from concrete flooring is harmful to electronic equipment and wiring. Make sure that the rack and any collocated equipment are protected prior to drilling holes in the concrete floor. Use a tarpaulin, cloth, or plastic sheeting to cover exposed equipment.

(The rack should be already covered with an antistatic bag; do not remove the bag at this time.) Use a vacuum while drilling the holes to minimize the spread of concrete dust. Carefully clean up any accumulated dust and debris from the anchor installation before uncovering the equipment.

12.2.2.3

Installing Cabinets

Each cabinet bottom is pre-drilled with four (4) mounting holes to allow attachment to the site floor. If installing on a concrete floor, use the cabinet as a template, mark the hole locations, and follow the procedures above for anchoring equipment racks. If installing on a wooden floor, use lag bolts and washers (customer supplied) to secure the cabinet to the floor.

12.2.2.4

Desk Mount

To use the repeater as a desk mount, install mounting brackets (PN: 07009401001) at a 90 degree angle as shown in [Figure 80: Desk Mount Installation on page 124](#) using two M4 screws (PN: 0310907A99) for each bracket using a T20 Torx driver at 15 in-lb (1.7 N-m). Then push a rubber foot (PN: 75009498001) into each bracket as shown in [Figure 80: Desk Mount Installation on page 124](#). Next push two rubber feet (PN: 75009502001) into the base frame also shown in [Figure 80: Desk Mount Installation on page 124](#).

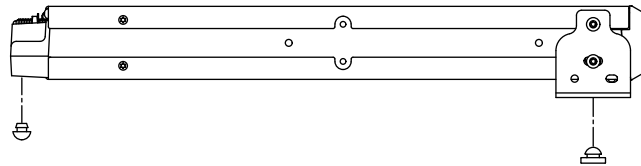
Figure 80: Desk Mount Installation

12.3

Electrical Connections

After the repeater equipment has been mechanically installed, electrical connections must be made.

This involves making the following connections to:

- power supply,
- antenna coax cables
- system cables, and
- grounding

Figure [Figure 81: Back Panel Connector Names and Locations on page 124](#) shows the position of the repeaters external connectors located on the back panel of the repeater. [Table 42: Connector Type and Primary Function on page 124](#) identifies the connector types as well as a given connector's primary function.

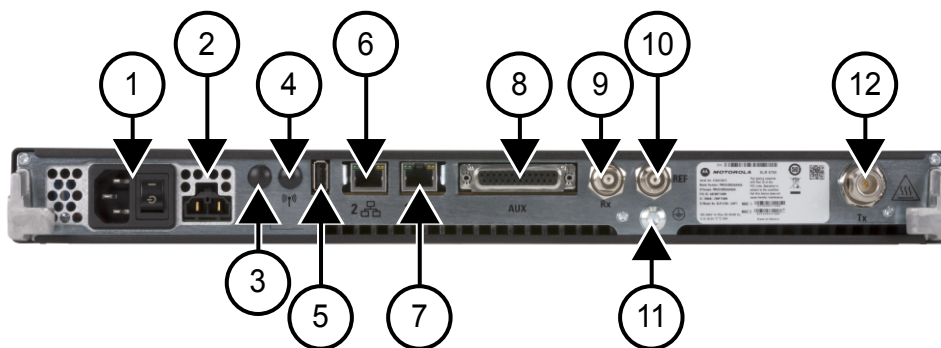
Figure 81: Back Panel Connector Names and Locations**Table 42: Connector Type and Primary Function**

Location	Connector Type	Function(s)
1	C14 (IEC 60320)	AC Power Inlet of Repeater Power Switch
2	Molex 42818-0212	DC Power Inlet and DC Charger Outlet

Table continued...

Location	Connector Type	Function(s)
3	Option Dependent	Option Dependent 1
4	Option Dependent	Option Dependent 2
5	Type A Socket	USB
6	RJ-45 – Jack	Ethernet 2
7	RJ-45 – Jack	Ethernet 1
8	DB25 – Female	Aux: Rx Audio, Tx Audio, PTT, COR, Accessory Power, 1 PPS, and GPIO
9	BNC – Female	Receiver RF (Rx)
10	BNC – Female	Frequency Reference Input (REF)
11	T30 TORX Screw	Bonding Ground Connection
12	N-Type – Female	Transmitter RF (Tx)

There is also a USB connection associated with maintenance and troubleshooting of the repeater. This connection is located on the front of the repeater. See [Figure 82: Location of USB Connector on page 125](#).

Figure 82: Location of USB Connector



Table 43: Callout Legend

Label	Description
1	USB Service Port

12.3.1

Power Supply Connections

12.3.1.1

AC Input Power Connection



CAUTION:

Do not apply AC power to the repeater at this time. Make sure that the circuit breaker associated with the AC outlet is turned OFF.

The AC socket-outlet must be installed near the equipment and must be easily accessible.

Each repeater is shipped with an 2.5 m (8 ft) 3-conductor line cord. See [Figure 81: Back Panel Connector Names and Locations on page 124](#) for AC power inlet connector. Insert the plug into an appropriate grounded outlet.

12.3.1.2

DC Input Power Connection/ DC Charger Connection

For DC operation, the DC source power is connected to the repeater through the DC power inlet connector shown in [Figure 81: Back Panel Connector Names and Locations on page 124](#). The operation is also described in the “Battery Connection” section of this chapter. The DC source must be located in the same building as the repeater, and it must meet the requirements of an SELV circuit.



CAUTION: Ensure that the appropriate voltage is connected with a nominal 13.6 VDC (11 – 14.4 VDC).

12.3.1.3

Ground Connection

The repeater is equipped with a ground screw located on the back panel. [Figure 81: Back Panel Connector Names and Locations on page 124](#) shows the location of the grounding screw. Connect the ground screw to the site ground point. The size of the wire used for this connection must be 8 AWG minimum.



CAUTION: Refer to Motorola Quality Standards Fixed Network Equipment Installation Manual R56 (which can be obtained by ordering CDR0M 9880384V83), for complete information regarding lightning protection.

The repeater should only be connected to a battery supply that is in accordance with the applicable electrical codes for the end use country; for example, the National Electrical Code ANSI/NFPA No. 70 in the U.S.

12.3.1.4

Battery Connection

Battery backup interface offers the capability of connecting to battery backup power in the event of an AC power line failure. The battery backup system is connected to the repeater through the DC inlet connector on the rear panel of the repeater. See [Figure 81: Back Panel Connector Names and Locations on page 124](#) for the location of the DC inlet connector.



CAUTION: The repeater should only be connected to a battery supply that is in accordance with the applicable electrical codes for the end use country; for example, the National Electrical Code ANSI/ NFPA No. 70 in the U.S.

12.3.1.5

RF Antenna Connections

The transmit and receive antenna RF connections are made using two separate connectors. Coax cables from the receive and transmit antennas must be connected to their respective connectors. The position of these connectors is shown in [Figure 81: Back Panel Connector Names and Locations on page 124](#), and their respective connector types are noted in [Table 42: Connector Type and Primary Function on page 124](#).

12.3.1.6

System Cable Connections

System connections are made through the Aux and/or Ethernet connectors located on the back panel of the repeater. The positions of the Aux and Ethernet connectors are shown in [Figure 81: Back Panel Connector Names and Locations on page 124](#).

See [Auxiliary \(Aux\) on page 71](#) for a description of the signaling that is supported by the Aux connector.

12.4

Post Installation Checklist

After the MOTOTRBO Repeater has been mechanically installed and all electrical connections have been made, power may now be applied and the repeater checked for proper operation.

12.4.1

Applying Power

Turn ON the circuit breaker controlling the AC outlet that is supplying power to the repeater Power Supply Module.

12.4.2

Verifying Proper Operation

Operation of the repeater can be verified by:

- Observing the state of the 7 LEDs located on the front panel, and
- Exercising radio operation



CAUTION: Some repeater components can become extremely hot during operation. Turn OFF all power to the repeater and wait until sufficiently cool before touching the repeater.



Symbol indicates areas of the product that pose potential burn hazards.

12.4.3

Front Panel LEDs

After turning ON the repeater power (or after a repeater reset), the 7 LEDs on the repeater front panel:

- Light for approximately one second to indicate that they are functional, then
- Go off for one second, then
- Indicate the operational status of the repeater.

12.4.4

Copying the Repeater Codeplug Data to a Computer

Backup the repeater's codeplug data by using the Customer Programming Software (CPS) on a computer.

12.5

Installing Repeater Hardware Options

12.5.1

General Bonding and Grounding Requirements

Cabinets and racks used to mount the repeater and optional equipment include a rack grounding bar with the capacity to terminate numerous ground wires. Equipment added to the cabinet or rack should be attached to the grounding bar using solid or stranded 6 AWG copper wires. See the Motorola Solutions R56 manual Standards and Guidelines for Communication Sites (which can be obtained by ordering CDRM 9880384V83) for more information on proper bonding and grounding at a site.

12.5.2

General Cabling Requirements

Diagrams for cabling are typically included in the system-specific configuration documentation provided by Motorola Solutions. Also see the Motorola Solutions R56 manual Standards and Guidelines for Communication Sites (which can be obtained by ordering CDROM 9880384V83) for cabling standards.

Appendix A : Accessories

Introduction

Motorola Solutions provides the following approved accessories to improve the productivity of the SLR 5000 Series Repeater.

For a list of Motorola-approved accessories, visit the following web site:
<http://www.motorolasolutions.com>

Cables

Part No.	Description
3087791G01	Power Cable, US
PMKN4167_	Battery Charger Cable
0112004B04	N-Type Male to N-Type Male Connector
0112004U04	N-Type Male to BNC Male Connector

Documentation

Part No.	Description
6880309T12	MOTOTRBO System Planner
9880384V83	CDROM for R56 manual
DSPDCRSS5	Asia MOTOTRBO CPS Subscription
GMLN4575_	MOTOTRBO Publication CD
GMVN5141_	MOTOTRBO Software DVD
GMVN5520_	MOTOTRBO RDAC Software CD
PMVN4130_	MOTOTRBO CPS/AirTacer CD
PMVN4171_	MOTOTRBO RDAC APP

Duplexers

Part No.	Description
9175300H01	VHF Duplexer (RoHS) 132–146 MHz
9175300H02	VHF Duplexer (RoHS) 144–160 MHz
9175300H03	VHF Duplexer (RoHS) 158–174 MHz
9175300H05	UHF Duplexer (RoHS) 403–435 MHz
9175300H06	UHF Duplexer (RoHS) 435–470 MHz
9175300H07	UHF Duplexer (RoHS) 470–494 MHz
9175300H08	UHF Duplexer (RoHS) 494–512 MHz

Table continued...

Part No.	Description
DSCP10725 Tuned	UHF Duplexer Tuned 406–500 MHz
DSCP10725 Untuned	UHF Duplexer Untuned 406–500 MHz
HFD8188_	VHF Duplexer, 144–155 MHz
HFD8189_	VHF Duplexer, 155–162 MHz
HFD8190_	VHF Duplexer, 162–174 MHz
HFD8465_	VHF Duplexer, 150–160 MHz
HFE8400_	UHF Duplexer, 406–450 MHz
HFE8401_	UHF Duplexer, 470–495 MHz

Mounting

Part No.	Description
PMLN6826_	Mounting Hardware Kit
BR000031A01	Mounting Bracket (Long, Rack Mount Shipping only)
PMLE4548_	Rack Mount Duplexer/Filter Enclosure Kit (includes mounting screws)
PMLE5031_	Wall Mount Bracket Kit

Preselectors

Part No.	Description
HFD8461_	VHF Preselector, 144–160 MHz
HFD8462_	VHF Preselector, 160–174 MHz
HFD8463_	VHF Preselector, 136–144 MHz
HFD8458_	UHF Preselector, 406–440 MHz
HFE8459_	UHF Preselector, 440–474 MHz
HFE8460_	UHF Preselector, 474–512 MHz

Service Parts

Part No.	Description
PMTD4012_S	SLR 5000 Series VHF PA Service Kit
PMTD4013_S	SLR 5000 Series VHF Modem Service Kit
PMTE4022_S	SLR 5000 Series UHF1 Modem Service Kit
PMTE4023_S	SLR 5000 Series UHF1 PA Service Kit
PMPN4026_S	SLR 5000 Series Power Supply Service Kit
PMLN6490_S	SLR 5000 Series Front Panel Board Service Kit

Table continued...

Part No.	Description
PMHN4299_	Chassis Service Kit (contact Motorola Solutions Service Center for replacement)
PMLN7244_	SLR 5000 Series Fan Assembly Service Kit

Service Tools

Part No.	Description
PMKN4166_	Test Cable (for test box and external speaker)
30009477001	USB A to USB B Cable (for programming)
RLN4460_	Test Box
RVN5115_	Portable, Mobile and Repeater Customer Programming Software (CPS) Package
HSN1006_	Speaker, Amplified
GMMN4063_	Microphone, RJ45

This page intentionally left blank.

Appendix B : Replacement Parts Ordering

Replacement Parts Ordering

This section describes ways you can place your orders for the replacement parts.

Basic Ordering Information

Some replacement parts, spare parts, and/or product information can be ordered directly. While parts may be assigned with a Motorola part number, this does not guarantee that they are available from Motorola Radio Products and Solutions Organization (RPSO). Some parts may have become obsolete and no longer available in the market due to cancelations by the supplier. If no Motorola part number is assigned, the part is normally not available from Motorola, or is not a user-serviceable part. Part numbers appended with an asterisk are serviceable by Motorola Depot only.

Motorola Online

Motorola Online users can access our online catalog at

<https://businessonline.motorolasolutions.com>

To register for online access, please call 1-800-422-4210 (for U.S. and Canada Service Centers only). International customers can obtain assistance at <https://businessonline.motorolasolutions.com>

Mail Orders

Mail orders are only accepted by the US Federal Government Markets Division (USFGMD).

Motorola
7031 Columbia Gateway Drive
3rd Floor – Order Processing
Columbia, MD 21046
U.S.A.

Telephone Orders

Radio Products and Solutions Organization*
(United States and Canada)
7:00 AM to 7:00 PM (Central Standard Time)
Monday through Friday (Chicago, U.S.A.)
1-800-422-4210
1-847-538-8023 (United States and Canada)

U.S. Federal Government Markets Division (USFGMD)
1-877-873-4668
8:30 AM to 5:00 PM (Eastern Standard Time)

Fax Orders

Radio Products and Solutions Organization*
(United States and Canada)
1-800-622-6210
1-847-576-3023 (United States and Canada)

USFGMD
(Federal Government Orders)
1-800-526-8641 (For Parts and Equipment Purchase Orders)

Parts Identification

Radio Products and Solutions Organization*
(United States and Canada)
1-800-422-4210

Product Customer Service

Radio Products and Solutions Organization (United States and Canada)
1-800-927-2744

⁹ * The Radio Products and Solutions Organization (RPSO) was formerly known as the Radio Products Services Division (RPSD) and/or the Accessories and Aftermarket Division (AAD).
Motorola Solutions Confidential

Appendix C : Motorola Service Centers

Motorola Service Centers

Servicing Information

If a unit requires further complete testing, knowledge and/or details of component level troubleshooting or service than is customarily performed at the basic level, please send the radio to a Motorola Service Center as listed below or your nearest Authorized Service Center.

Motorola Service Center

1220 Don Haskins Drive
Suite A
El Paso, TX 79936
Tel: 915-872-8200

Motorola Federal Technical Center

10105 Senate Drive
Lanham, MD 20706
Tel: 1-800-969-6680
Fax: 1-800-784-4133

Motorola Canadian Technical Logistics Center

181 Whitehall Drive
Markham, Ontario,
L3R 9T1
Toll Free: 800-543-3222

This page intentionally left blank.

Appendix D : SLR 5000 Series Third-Party Controllers

Overview

The SLR 5000 Series Repeater is capable of interfacing to a number of third party controllers via the four-wire and GPIO/GPI interface afforded by the back panel AUX connector. This section covers the connections and signal levels between the third party controllers and the repeater, as well as the audio path configuration needed via CPS. Note that this section is not a substitute for a more comprehensive instruction detailed in the vendor's manuals of their respective third party controllers.

The third party controllers supported by SLR 5000 Series Repeater are as follows:

- Community Repeater Panel (Zetron Model 38-Max)
- Phone Patch (Zetron Model 30)
- Tone Remote Adapter (Motorola Model L3276)
- LTR (Trident Model Raider and Marauder)
- Passport (Trident Model NTS) (see Note)



CAUTION: Do not hot swap any of the third party controllers as this could (at a minimum) cause a malfunction with the repeater.



NOTICE: The SLR 5000 Series Repeater only support the third party controllers noted above when it is configured in analog mode. The screen capture below shows the CPS location to configure the SLR 5000 Series Repeater for analog mode.

If the third party controllers are supplied power by the SLR 5000 Series Repeater, then the SLR 5000 Series Repeater needs to be in a powered off state when establishing (or removing) the connection to the SLR 5000 Series back panel connector.

Figure 83: CPS Settings to Configure SLR 5000 Series Repeater for Analog Mode

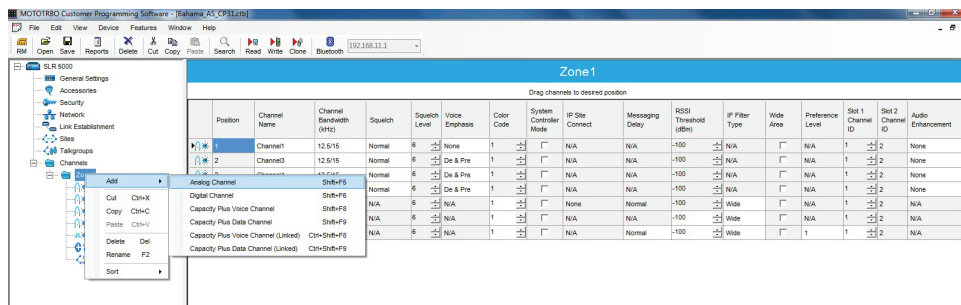

Community Repeater Panel

Description

The SLR 5000 Series Repeater is capable of Multi Coded Squelch through the Zetron Model 38 Repeater Panel. The Model 38 Repeater Panel interconnects to the SLR 5000 Series Repeater and provides 38 PL tones and 22 DPL tones standard.

See Zetron Model 38 Repeater Panel Instruction Manual (supplied with the panel) for panel specifications, operation, installation, alignment, programming, and repair information.

Figure 84: Model Zetron 38 Repeater Panel



Compatibility

Zetron Model 38 Repeater Panel is compatible for all versions of SLR 5000 Series software and hardware.

Hardware Connections

The connections between the SLR 5000 Series Repeater and the community repeater panel are facilitated with a multi-conductor cable connected between the SLR 5000 back panel AUX 25-Pin connector and that of the community repeater panel. The connection provides the following signals:

- Transmit Audio
- Receiver Audio
- Push-to-talk (PTT)
- Carrier Operated Relay (COR)
- 13.6 VDC nominal (See note)
- Ground



NOTICE: If this connection is used, the external equipment must draw less than 1A.

Signal connections are noted in [Figure 83: CPS Settings to Configure SLR 5000 Series Repeater for Analog Mode on page 137](#). The SLR 5000 Series connector and physical Pin locations are noted in the backplane interface board section of this manual. See Zetron Model 38 Repeater Panel manual for its connector and physical Pin locations. The part number for a pre-fabricated cable is noted in the SLR 5000 Series ordering guide.

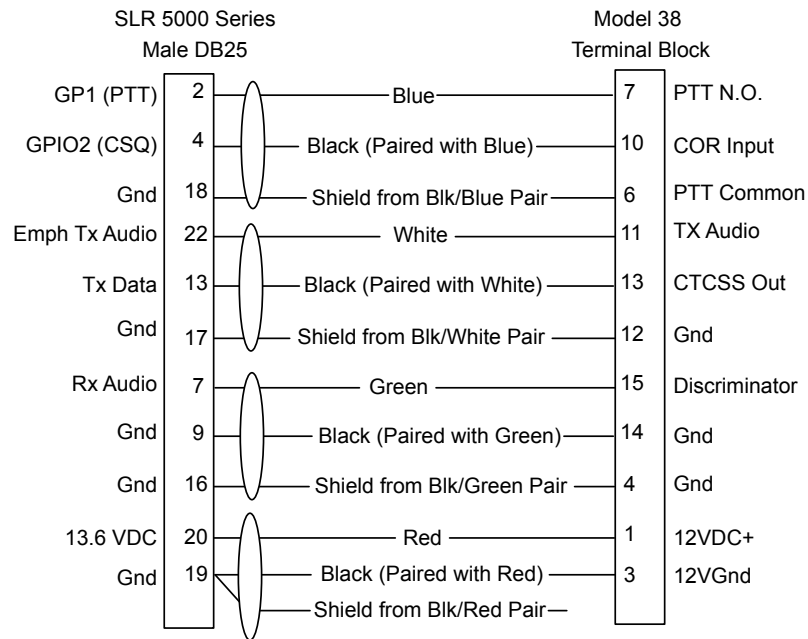
Figure 85: Signal Connections between SLR 5000 Series Repeater and Community Repeater Panel

CPS Configuration

The SLR 5000 Series Repeater will need to be configured via the CPS application as shown in [Figure 86: CPS Configuration for Community Repeater Panel \(1 of 2\) on page 140](#) and [Figure 87: CPS Configuration for Community Repeater Panel \(2 of 2\) on page 140](#). More specifically, the affected parameters are as follows:

- Audio Type
 - Flat Unsquelled
- Disable Repeat Path
 - Checked
- GPIO Pin number 2, 11
 - Ext PTT
 - Active Low
- GPIO Pin number 4
 - Carrier Squelch (CSQ) Detect
 - Active High
- Squelch Type (Rx)
 - CSQ
- Squelch Type (Tx)
 - CSQ

Figure 86: CPS Configuration for Community Repeater Panel (1 of 2)

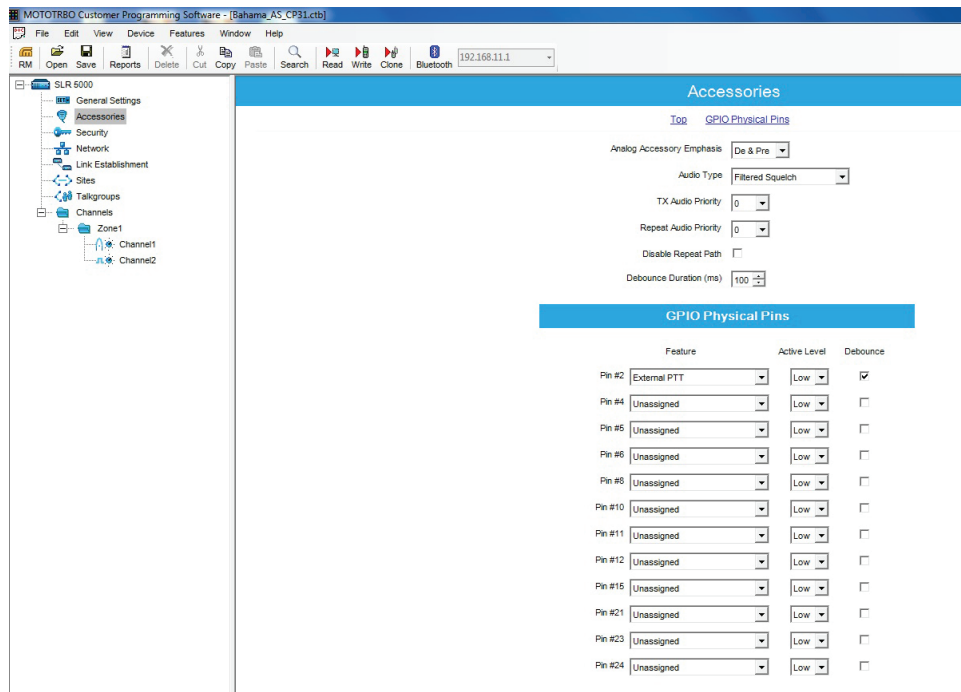
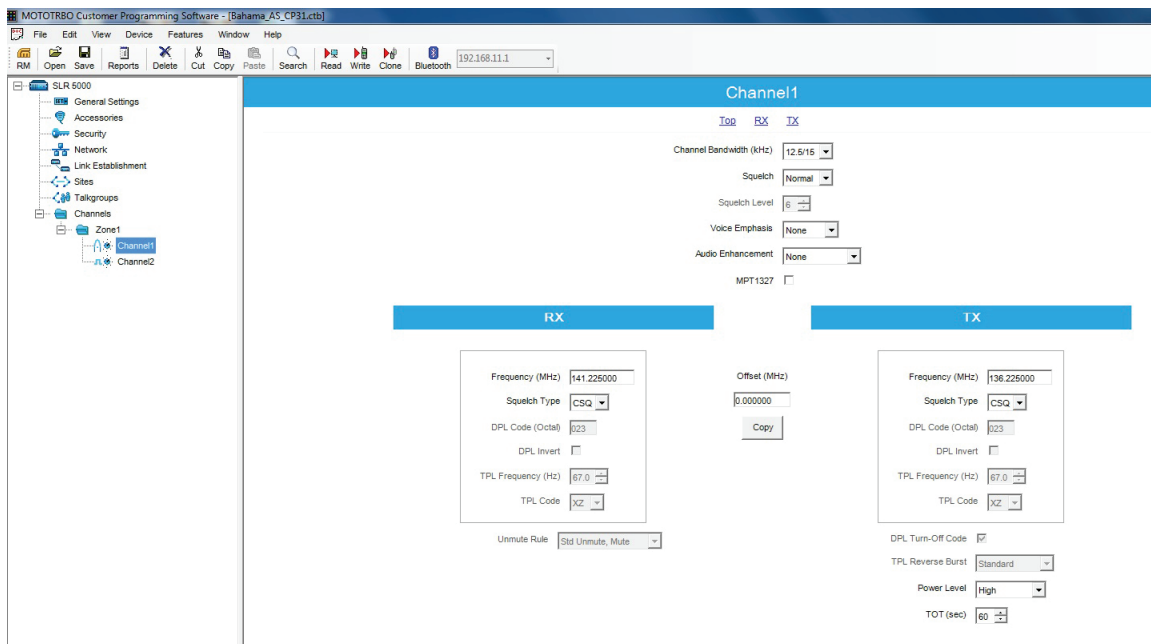

Figure 87: CPS Configuration for Community Repeater Panel (2 of 2)



Community Repeater Panel Settings

The input and output levels should be adjusted per the community repeater panel's instructions. The summary below gives a brief overview of the high level characteristics and community repeater panel settings for configuration with the SLR 5000 Series Repeater.

Discriminator

The SLR 5000 Series Repeater's Receiver audio will yield 330mV rms into 50 k Ω with an RF input signal deviating at 60% RSD. With the community repeater panel's own loading impedance, the "Discriminator" signal delivered to the community repeater panel is at a high enough drive level to leave the community repeater panel's "Rx Audio Gain High/Low" switch in the factory default position (back panel Switch 1).



NOTICE: Under the System Programming, turn on the DCS Rx data.

Tx Audio

The SLR 5000 Series Repeater's transmitter will yield 60% RSD with 80mV rms into the Emph Tx Audio port. The "Tx Audio" signal delivered by the community repeater panel is at a high enough drive level to leave the community repeater panel's "Tx Audio Gain High/Low" switch in the factory default position (back panel Switch 4).



NOTICE: Under the System Programming, turn on the DCS Tx data.

Continuous Tone-Controlled Squelch Systems (CTCSS) Out

The SLR 5000 Series Repeater's transmitter will yield 60% RSD with 80mV rms into the Tx Data port. The "CTCSS" signal delivered by the community repeater panel is at a high enough drive level to leave the community repeater panel's "Encode gain high/low" switch in the factory default position (back panel Switch 3).

Tx Audio Pre-Emphasis

Set the "Encode flat/ De-emphasized" switch to the Up position on the community repeater panel.

Carrier Operated Relay (COR)

For use with the SLR 5000 Series Repeater, configure the specified back panel switches on the community repeater panel as follows:

- Switch 6 "COR source internal/external" (set to the Down position)
- Switch 7 "COR polarity positive/negative" (set to the Up position)
- Switch 8 "COR pull-up on/off" (set to the Up position)

Phone Patch

Description

The SLR 5000 Series Repeater is capable of multi-mode telephone interconnect through the Zetron Model 30 Phone Patch. The Zetron Model 30 Phone Patch interconnects to the SLR 5000 Series Repeater and allow users to initiate and receive land line telephone calls via the subscriber radios. When properly configured, subscribers can initiate and answer telephone calls. Via selective signaling, calls from land line users can be directed to any subscriber or to a specific user. Additionally, access control is also afforded by the Zetron Model 30 Phone Patch.

See Zetron Phone Patch Manual (supplied with the phone patch) for specifications, operation, installation, alignment, programming, and repair information.

Figure 88: Zetron Model 30 Phone Patch



Compatibility

Zetron Model 30 Phone Patch is compatible for all versions of SLR 5000 Series Software and Hardware.

Hardware Connections

The connections between the SLR 5000 Series Repeater and the phone patch are facilitated with a multi-conductor cable connected between the J7 SLR 5000 Series back panel Aux 25-Pin connector and that of the phone patch. The connection provides for the following signals:

- Transmit Audio
- Receiver Audio
- PTT
- COR
- 13.6 VDC Nominal (see Note)
- Ground



NOTICE: If this connection is used, the external equipment must draw less than 1A.

Signal connections are noted in [Figure 84: Model Zetron 38 Repeater Panel on page 138](#). The SLR 5000 Series Repeater connector and physical Pin locations are noted in the backplane interface board section of this manual. See Zetron Model 30 manual for its connector and physical Pin locations. The part number for a pre-fabricated cable is noted in the SLR 5000 Series ordering guide.

Figure 89: Signal Connections between SLR 5000 Series Repeater and Zetron Model 30 Phone Patch (Analog Phone Patch Cable & Digital Phone Patch Cable)

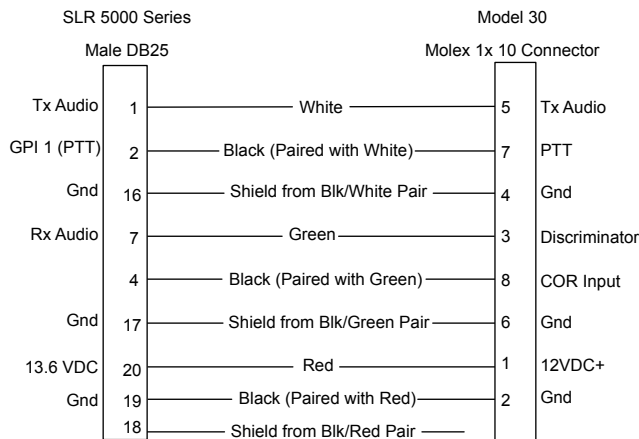

CPS Configuration

The SLR 5000 Series Repeater will need to be configured via the CPS application as shown in [Figure 86: CPS Configuration for Community Repeater Panel \(1 of 2\) on page 140](#) and [Figure 87: CPS Configuration for Community Repeater Panel \(2 of 2\) on page 140](#). More specifically, the affected parameters are as follows:

- Audio Type
 - Filtered Squelch
- Analog Accessory Emphasis
 - De & Pre
- Disable Repeat Path
 - Un-Checked
- Tx Audio Priority
 - 0
- GPIO Pin number 2, 11
 - Ext PTT
 - Active Low
- GPIO Pin number 4
 - PL/Talkgroup Detect
 - Active Low
- Squelch Type (Rx)
 - TPL
- Squelch Type (Tx)
 - TPL

Figure 90: CPS Configuration for Phone Patch (1 of 2)

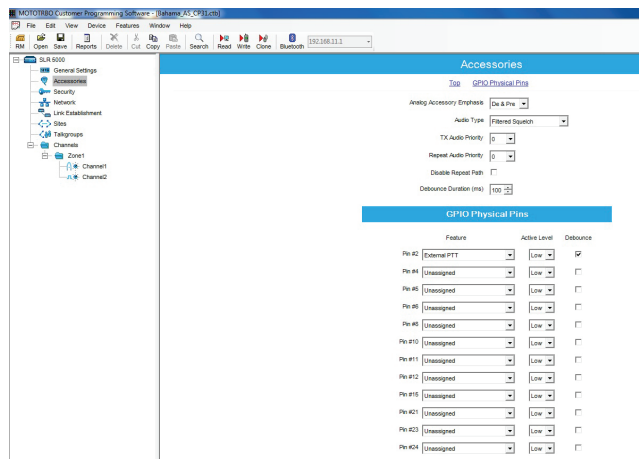
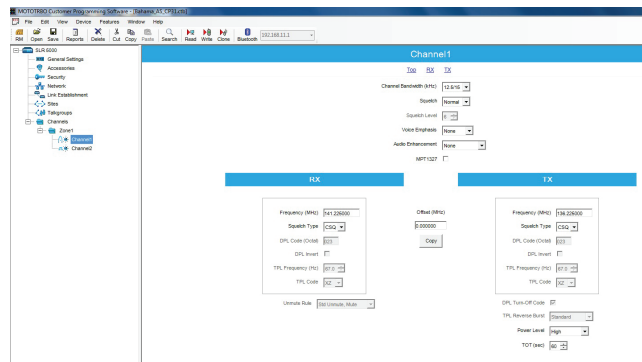

Figure 91: CPS Configuration for Phone Patch (2 of 2)



Phone Patch Level Settings

The input and output levels should be adjusted per the phone patch's instructions. The summary below gives a brief overview of the high level characteristics and phone patch settings for configuration with the SLR 5000 Series.

Disc

The SLR 5000 Series Repeater's Receiver audio will yield 330mV rms into 50 k Ω with an RF input signal deviating at 60% RSD. With the phone patch's own loading impedance, the "Disc" signal delivered to the phone patch is at a high enough drive level to leave jumper JP1 in the factory default position (position A).

Tx Audio

The SLR 5000 Series Repeater's transmitter will yield 60% RSD with 80mV rms into the Tx Audio port. The "Tx Aud" signal delivered by the phone patch is at a high enough drive level to leave jumper JP3 in the factory default position (position B).

CTCSS/ DCS DECODE INPUT/ COR

Set jumper JP6 to position A, to match the SLR 5000 Series' active low indication of a PL/DPL detect.

Set jumper JP7 to position B, to external squelch indication.

Set jumper JP8 to position C, to match the SLR 5000 Series' active low indication of a COR detect.

Tone Remote Adapter

Description

When a dispatch console or deskset sends out signals to a remote repeater, it does so over a Wireline. Two types of signals are sent:

- Audio signal
- Command signals (function tones) that are used to perform the remote control functions.

The SLR 5000 Series Repeater is capable of decoding function tones, sent over a Wireline from a remote analog deskset or console, via the Motorola Tone Remote Adapter (Model L3276). When properly configured, the Tone Remote Adapter will perform the following functions in conjunction with the SLR 5000 Series Repeater:

- Transmit and Receive Audio

- PTT
- Monitor
- Channel Select (up to 15 frequencies)
- Wildcard (e.g. Repeater Knockdown)

See Motorola Tone Remote Adapter Manual (supplied with the Tone Remote Adapter) for specifications, operation, installation, alignment, programming, alternate configurations, and repair information.

Figure 92: Model L3276 Tone Remote Adapter

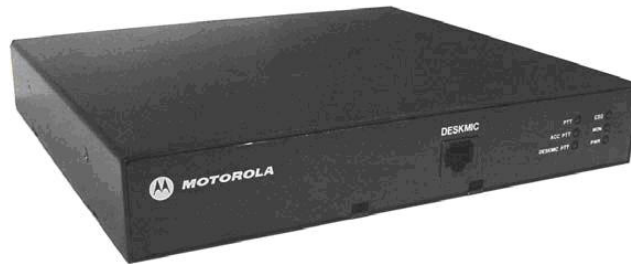

Compatibility

Model L3276 Tone Remote Adapter is compatible for all versions of SLR 5000 Series Software and Hardware.

Hardware Connections

The connections between the SLR 5000 Series Repeater and the Tone Remote Adapter are facilitated with a multi-conductor cable connected between the J7 SLR 5000 Series back panel AUX 25-Pin connector and that of the Tone Remote Adapter. The connection provides for the following signals:

- Transmit Audio
- Receiver Audio
- PTT
- COR
- Monitor
- Channel Steering
- Wild Card (E.g. Repeater Knockdown)
- Ground

Signal connections are noted in [Figure 85: Signal Connections between SLR 5000 Series Repeater and Community Repeater Panel on page 139](#). SLR 5000 Series Repeater connector and physical Pin locations are noted in the backplane interface board section of this manual. See Motorola L3276 25-Pin manual for its connector and physical Pin locations. The part number for a pre-fabricated cable is noted in the SLR 5000 Series ordering guide.

Figure 93: Signal Connections between SLR 5000 Series Repeater and Motorola L3276 25-Pin connector for a 15 Channel Remote Control

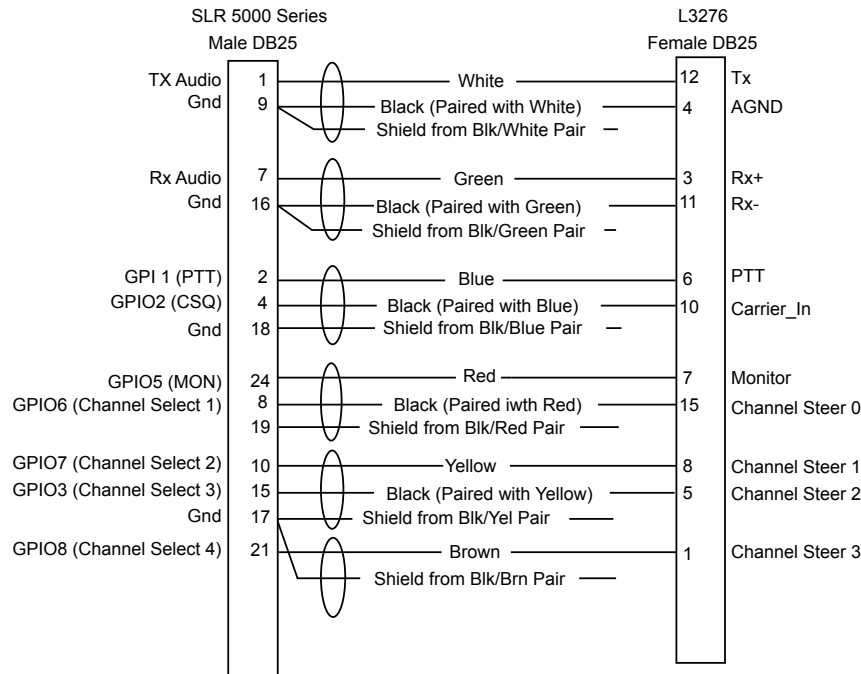

CPS Configuration (For a 15 Channel Remote Control)

The SLR 5000 Series Repeater will need to be configured via the CPS application as shown in [Figure 94: CPS Configuration for L3276 Tone Remote Adapter \(For a 15 Channel Remote Control\)](#) on page 147. More specifically, the affected parameters are as follows:

- Audio Type
 - Filtered Squelch
- Analog Accessory Emphasis
 - De & Pre
- Disable Repeat Path
 - Un-Checked or Checked
- Tx Audio Priority
 - Set to 0 for console priority
- GPIO Pin number 2, 11
 - Ext PTT
 - Active Low
- GPIO Pin number 4
 - CSQ Detect or PL/ Talk group Detect
 - Active Low
- GPIO Pin number 24
 - Monitor
 - Active Low

- GPIO Pin number 8, 25
 - Channel Select 1
 - Active Low
- GPIO Pin number 10, 12
 - Channel Select 2
 - Active Low
- GPIO Pin number 15
 - Channel Select 3
 - Active Low
- GPIO Pin number 21
 - Channel Select 4
 - Active Low

**Figure 94: CPS Configuration for L3276 Tone Remote Adapter
(For a 15 Channel Remote Control)**

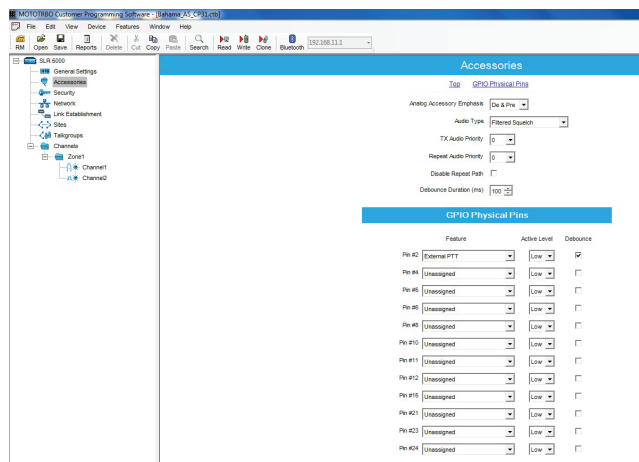

NOTICE: The above configuration is considered typical. The L3276 Remote Tone Adapter provides alternate configurations that are supported by SLR 5000 Series Repeater as well. See L3276 Remote Tone Adapter Manual for additional details.

Tone Remote Adapter settings

The input and output levels should be adjusted per the Tone Remote Adapter's instructions. The summary below gives a brief overview of the high level characteristics and typical Tone Remote Adapter settings for configuration with the SLR 5000 Series Repeater.

Radio Rx

The SLR 5000 Series Repeater's Receiver audio will yield 330mV rms into 50 k Ω with an RF input signal deviating at 60% RSD. With the Remote Tone Adapter's own loading impedance, the "Radio Rx" signal delivered to the phone patch is at a high enough drive level to leave jumper S10 in the factory default position (position is "out").

Radio Tx

The SLR 5000 Series Repeater's transmitter will yield 60% RSD with 80mV rms into the Tx Audio port. The "Radio Tx" signal delivered by the Remote Tone Adapter is at a high enough drive level to leave jumper S9 in the factory default position (position A).

Channel Steering

Leave jumper S7 in position B (factory default) to match the SLR 5000 Series Repeater's active low setting for the Channel Steering 1, Channel Steering 2, Channel Steering 3, and Channel Steering 4 GPIO signaling.

Monitoring

Leave jumper S8 in the "IN" position (factory default) to match the SLR 5000 Series' active low setting for the Monitor GPIO signaling.

PTT

Leave jumper S5 in the "IN" position (factory default) to match the SLR 5000 Series' active low setting for the PTT GPIO signaling.

Wildcard 1 (optional)

Leave jumper S6 in position A (factory default) to match the SLR 5000 Series' active low setting for the Repeater Disabled GPIO signaling.

Trunking Controllers

Description

The SLR 5000 Series Repeater is capable of supporting LTR trunking operations with the Trident's Marauder and Raider controllers. Additionally, the SLR 5000 Series Repeater also supports Passport trunking as well with Trident's NTS controller.

See respective Trident Instruction Manuals (supplied with the controllers) for specifications, operation, installation, alignment, programming, and repair information.

Figure 95: Model Trident's Marauder



Figure 96: Model Trident's Raider



Figure 97: Model Trident's NTS

Compatibility

Trident Model Raider, Marauder and NTS are compatible for all versions of SLR 5000 Series Software and Hardware.

Hardware Connections

The connections between the SLR 5000 Series Repeater and the trunking controllers are facilitated with a multi-conductor cable connected between the J7 SLR 5000 Series back panel AUX 25-Pin connector and that of the connector on the trunking controller. The connection provides for the following signals:

- Transmit Audio
- Transmit Data
- Receiver Audio
- PTT
- 13.6 VDC (see Note)
- Ground



NOTICE: If this connection is used, the external equipment must draw less than 1A. This connection is not supported for the NTS controller.

Signal connections are noted in [Figure 86: CPS Configuration for Community Repeater Panel \(1 of 2\) on page 140](#). The SLR 5000 Series Repeater connector and physical Pin locations are noted in the backplane interface board section of this manual. See the Trident manuals for their respective connector and physical Pin locations. The part number for a pre-fabricated cable is provided in the respective Trident manuals.

Figure 98: Signal connections between SLR 5000 Series Repeater, Trident Model Raider, Marauder and NTS

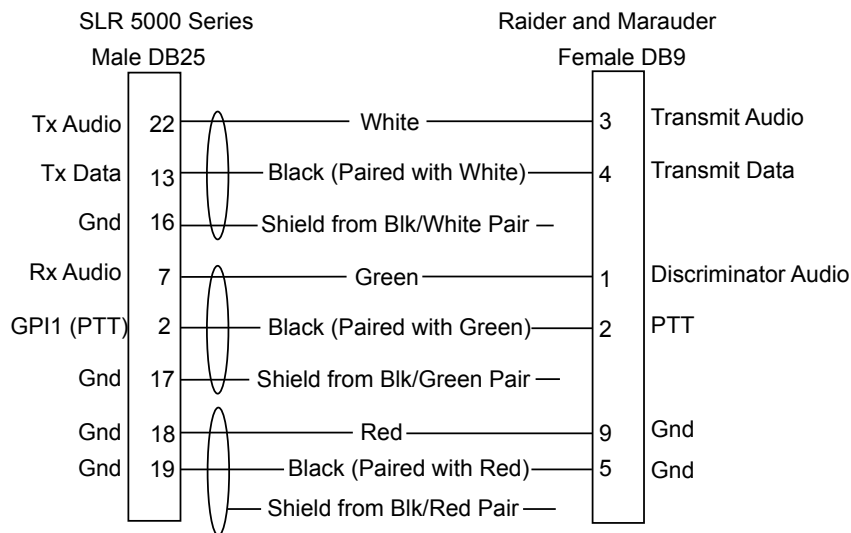
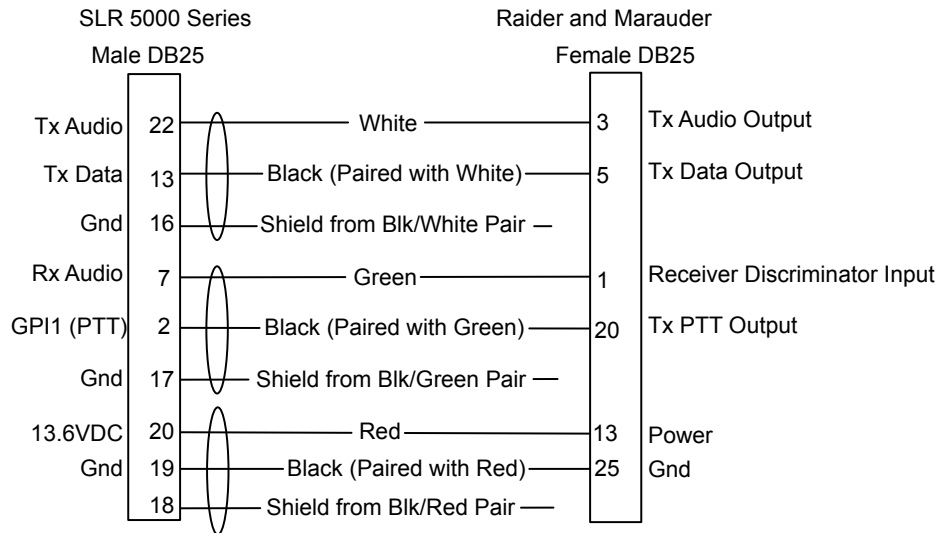

CPS Configuration

The SLR 5000 Series will need to be configured via the CPS application as shown in the figures below. More specifically, the affected parameters are as follows:

- Audio Type
 - Flat Unsquelled
- Disable Repeat Path
 - Checked
- GPIO Pin number 2
 - Ext PTT
 - Active Low

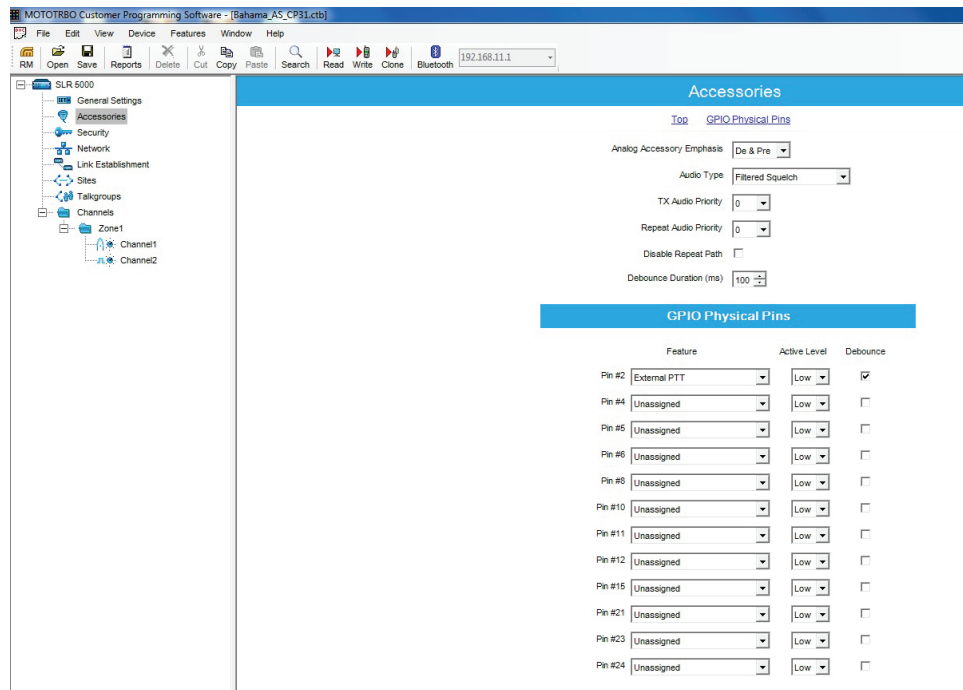
Figure 99: CPS Configuration for Trident Model Raider, Marauder and NTS

Trunking Controller Settings

The input and output levels should be adjusted per the trunking controller's instructions. The summary below gives a brief overview of the high level characteristics and trunking controller settings for configuration with the SLR 5000 Series Repeater.

Discriminator

The SLR 5000 Series Repeater's Receiver audio will yield 330 mV rms into 50 k Ω with an RF input signal deviating at 60% RSD. With the trunking controller's own loading impedance, the "Discriminator" signal delivered to the trunking controller will need to be boosted by setting the following jumpers in the noted position:

- Marauder and Raider
 - W22: OUT position
 - W30: IN position

Tx Audio

The SLR 5000 Series Repeater's transmitter will yield 60% RSD with 80 mV rms into the Emph Tx Audio port. No range setting is provided in the trunking controller for the Tx Audio, rather the level is solely controlled by a singular potentiometer or soft-potentiometer.

Tx Data

The SLR 5000 Series Repeater's transmitter will yield 60% RSD with 80 mV rms into the Tx Data port. No range setting is provided in the trunking controller for the Tx Data, rather the level is solely controlled by a singular potentiometer or soft-potentiometer.

- Marauder, Raider and NTS
 - Data needs to be inverted

- NTS needs to be set for DSP operation (Channel card setting)

Appendix E : Audio Enhancement

Overview

The Hear Clear, Flutter Fighter, and Companding features improve analog audio quality in a multi-path fading environment. The Hear Clear (Companding and Flutter Fighter activated together) and Flutter Fighter features are only available in the 800 and 900 MHz bands, while the Companding feature is available for all bands.

Hear Clear feature with the third party controllers

The Hear Clear feature is only available to third party controllers without the data such as phone patch and Tone remote Adaptor.

Third Party Controller	Hear Clear Configuration for Third Party Box	Flutter Fighter
Community Repeater Panel	Not selectable	Selectable
Trident's Marauder controller	Not selectable	Selectable
Trident's Raider controller	Not selectable	Selectable
Phone Patch	Selectable	Selectable
Tone Remote Adaptor	Selectable	Selectable

Third party controller and the subscriber configuration for Hear Clear feature

The Hear Clear feature requires matching configuration between the SLR 5000 Series Repeater that supports third party controllers and the subscribers.

SLR 5000 Series with Phone Patch/Tone Remote Adapter	Subscriber
Hear Clear	Hear Clear
Flutter Fighter	Flutter Fighter
None	None

Hear Clear feature configuration in repeater mode

The Hear Clear feature requires matching configurations between the subscribers.

Repeater mode		
Subscriber 1	Repeater	Subscriber 2
Hear Clear	Hear Clear	Hear Clear
Flutter Fighter	Hear Clear	Flutter Fighter
None	Hear Clear	None

Comanding feature configuration between third party controllers and subscriber

The companding feature requires matching configuration between the third party controllers and the subscriber.

SLR 5000 Series with Phone Patch/Tone Remote Adapter	Subscriber
Comanding	Comanding
None	None

Comanding feature configuration between the repeater and subscribers

The companding feature requires matching configurations between the subscribers.

Repeater mode		
Subscriber 1	Repeater	Subscriber 2
Comanding	Hear Clear	Comanding
None	Hear Clear	None

Appendix F : MOTOTRBO Repeater – EME ASSESSMENT



NOTICE: The example given in this Appendix applies for a UHF band system. For different frequency bands, applicable band-specific parameters should be employed to carry out the computations yielding band-specific compliance boundaries.

Executive Summary

The Electromagnetic Energy (EME) compliance boundaries in a typical system configuration of the Motorola MOTOTRBO SLR 5000 Series Repeater described in the following are derived.

Compliance is established with respect to the applicable limits defined in the ICNIRP guidelines [1], the United States regulations [2]-[3], and in the CENELEC Standards EN50384:2002 [5] and EN50385:2002 [6]. These standards and regulations apply to occupational and general public EME exposure.

The assessment was carried out using a computational method described in the CENELEC Standard EN50383:2010 [4], which is referenced by the EN50385:2002, and this report has been drafted in accordance with its requirements. Thus the assessment and report address the European Radio and Telecommunications Terminal Equipment (R&TTE) Directive requirements concerning EME exposure.

The following table provides the compliance distances for general public and occupational-type exposure, for the UHF frequency band, antenna, and parameters considered in this analysis, based on a typical system configuration:

Table 44: EME Compliance Distances Based on Example UHF Evaluation

Compliance distances	Antenna front (Andrew mod. DB408)	Ground level (20 m below antenna)
General public exposure	6.9 m	Always compliant
Occupational-type exposure	2.15 m	Always compliant

Exposure Prediction Model

Exposure in Front of the Antenna

The cylindrical-wave model defined in Clause 8.3.4 of the EN50383:2010 standard is applied to determine the compliance boundaries for workers and general public for a typical system configuration of the MOTOTRBO SLR 5000 Series Repeater.

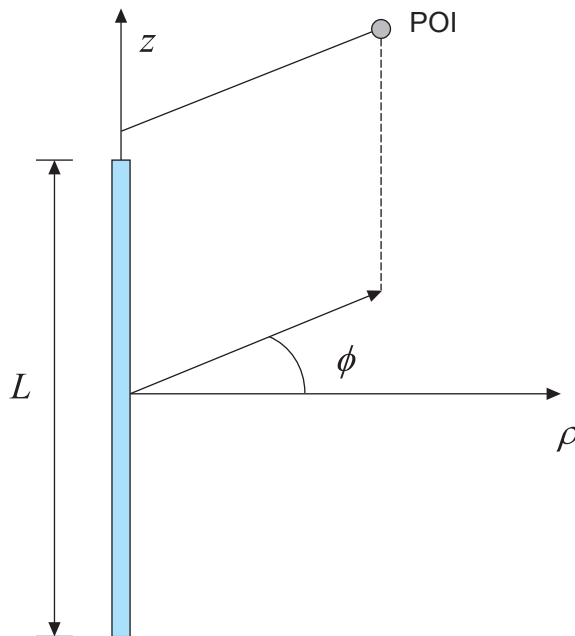
Figure 100: Reference frame for the point of interest (POI) cylindrical co-ordinates

Per the reference frame in [Figure 100: Reference frame for the point of interest \(POI\) cylindrical co-ordinates on page 156](#), the cylindrical-wave model is applicable in the volume described in cylindrical

co-ordinates (ρ, ϕ, z) for omni-directional array antennas as follows:

$$\hat{S}(r, \phi) = \frac{P}{\pi r L \cos^2 \gamma \sqrt{1 + \left(2 \frac{r}{r_0}\right)^2}}, \quad r_0 = \frac{1}{2} D_A L \cos^2 \gamma$$

where

P
available power at the antenna port (W);

L
physical antenna length (metres);

D_A
peak antenna directivity (unit-less), assumed equal to the peak gain G_A ;

γ
electrical down-tilt angle of the antenna main beam (radians), and

$$r = \frac{\rho}{\cos \gamma}$$

is the distance from the antenna center (metres). Spatial power density averaging may be required by some regulations. As the formula (1) predicts the peak power density, it represents a conservative estimate of the average power density. Thus there is no need to compute the latter.

Exposure at Ground Level

Several methods can be employed to determine the EME exposure at ground level. Such an assessment is not necessary if the mounting height of the antenna is larger than the compliance distance in front of the antenna, computed using the EN50383:2010 methodology outlined in [Exposure in Front of the Antenna on page 155](#). If this is not feasible, then the following approach can be employed.

At ground level exposure occurs in the antenna far-field. The antenna phase center is assumed to be the mounting height. The resulting predictive equation for the power density is:

$$S(d) = (2.56) \frac{P \cdot G(\theta)}{4\pi(H^2 + d^2)}$$

where $G(\theta)$ is the elevation gain pattern, which is approximated by the following expression:

$$G(\theta) = G_A \left| \frac{\sin\left(\frac{k_0 L}{2} \sin\theta\right)}{\frac{k_0 L}{2} \sin\theta} \right|^2$$

where $k_0 = 2\pi/\lambda$ is the free-space wavenumber and L is the effective antenna length yielding the appropriate vertical beamwidth, while H is the antenna height above ground and d is the point of interest (POI) distance from the vertical antenna projection to ground (see [Figure 101: Schematic of the ground-level exposure model adopted for the assessment on page 157](#)). The multiplicative factor 2.56 is introduced to enforce near-perfect, in-phase ground reflection as recommended in [2]. In this case, spatial averaging is not carried out to make the EME exposure assessment more conservative.

Figure 101: Schematic of the ground-level exposure model adopted for the assessment

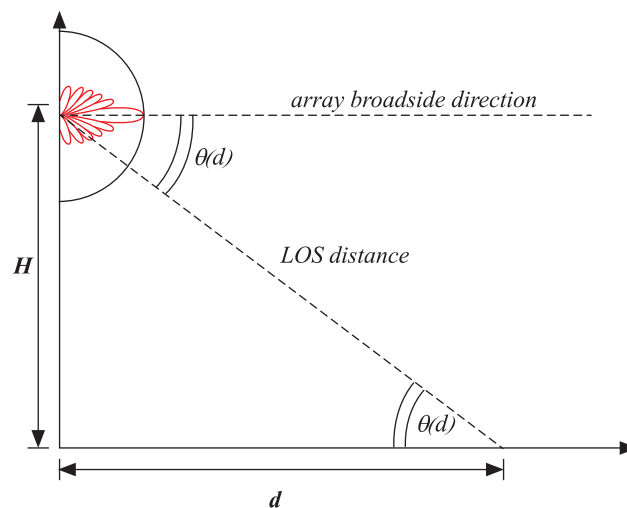

Typical System Configuration

The MOTOTRBO SLR 5000 Series Repeater operates in different frequency ranges with different channels transmitting 100 W radio frequency (RF) power. The typical system configuration comprises an omnidirectional array antenna featuring 6–10 dBd gain, installed at or above 20 m from ground level, and fed by the SLR 5000 Series Repeater through a combiner characterized by a typical 3 dB transmission loss, and a 30 m 7/8" coaxial cable characterized by a typical 2.7 dB/100m loss, resulting in a total 3.9 dB transmission loss. Based on these characteristics, the RF power at the antenna input is about 200 W.

Since shorter antennas provide a conservative EME exposure assessment from equation (1), when

$$r < r_0$$

, the parameters of a typical 6.6 dBd antennas are employed (it will have to be verified that

the resulting compliance distances are indeed smaller than r_0). Such an antenna (e.g., Andrew DB408) would exhibit a typical elevation beamwidth of about 14 degrees.

Exposure Limits

Based on the SLR 5000 Series operating frequency range, the most conservative power density limits are those defined in the ICNIRP guidelines [1]. They are 10.1 W/m² for occupational exposure, and 2.02 W/m² for general public exposure. They will be used for the EME exposure assessment.

EME Exposure Evaluation

Exposure in Front of the Antenna

The assessment is based on the following characteristics of the Andrew DB408 antenna:

$$G_A = 10^{\frac{6.6+2.15}{10}} = 7.5 \quad P = 200 \text{ W} \quad \gamma = 0 \quad L = 2.7 \text{ m}$$

The parameter r_0 is thus $r_0 = 10.1 \text{ m}$. Upon inserting the power density limits established in [Exposure Limits on page 158](#) into formula (1), the following distances for occupational and general public exposure compliance are respectively determined:

$$r_{\text{occupational}} = 2.15 \text{ m}$$

and

$$r_{\text{general public}} = 6.9 \text{ m}$$

As both these distances are less than r_0 , the aforementioned choice ([Typical System Configuration on page 158](#)) of considering the shorter, lower gain antenna to perform the assessment is deemed valid. Longer, higher gain antennas would yield shorter compliance distances, for the same input antenna power and operating frequency range.

Exposure at Ground Level

Since the antenna installation height above ground level in the typical system configuration (20 m) is larger than either of the compliance distances determined in [Exposure in Front of the Antenna on page 158](#), the EME exposure at ground level is always compliant with the exposure limits defined in the ICNIRP guidelines.

Compliance Boundary Description

Based on the analysis in [EME Exposure Evaluation on page 158](#), the compliance boundaries for occupational and general public exposure are defined as cylinders enclosing the antenna (see [Figure 102: Compliance boundary for general public \(GP\) and occupational \(OCC\) exposure on page 159](#)), extending 75 cm (one wavelength) above and below the physical antenna, with radii:

Occupational exposure:

$$\rho_{OCC} = 2.15 \text{ m}$$

General Public exposure:

$$\rho_{GP} = 6.9 \text{ m}$$

Figure 102: Compliance boundary for general public (GP) and occupational (OCC) exposure

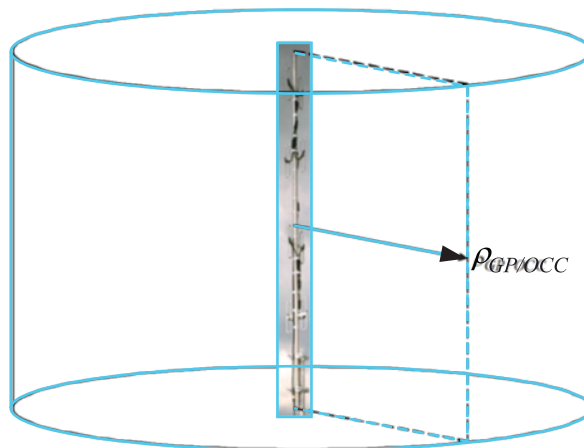

Product Put In Service

Some regulations require that additional exposure assessments be performed when putting the product in service, to account for antenna site-specific circumstances such as the environment (e.g. electromagnetic scatterers) and other antennas. In such cases, certain standards [7]–[10] may need to be considered to determine the most suitable compliance assessment methodology.

References

Procedure:

- 1 International Commission on Non-Ionizing Radiation Protection (ICNIRP), "Guideline for Limiting Exposure to Time-Varying Electric, Magnetic, and Electromagnetic Fields," Health Physics, vol. 74, no. 4, pp. 494-522, April 1998.
- 2 United States Federal Communication Commission, "Evaluating compliance with FCC guidelines for human exposure to radio frequency electromagnetic fields," OET Bulletin 65, Ed. 97-01, Section 2 (Prediction Methods), August 1997.
- 3 US Code of Federal Regulations, Title 47, Volume 1, Sec. 1.1310 Radio frequency radiation exposure limits (Revised as of October 1, 2003).
http://edocket.access.gpo.gov/cfr_2003/octqtr/47cfr1.1310.htm.
- 4 EN 50383:2010. Basic standard for the calculation and measurement of electromagnetic field strength and SAR related to human exposure from radio base stations and fixed terminal stations for wireless telecommunication systems (110 MHz – 40 GHz). CENELEC (European Committee for Electrotechnical Standardization).
- 5 EN 50384:2002. Product standard to demonstrate the compliance of radio base stations and fixed terminal stations for wireless telecommunication systems with the basic restrictions or the reference levels related to human exposure to radio frequency electromagnetic fields (110 MHz – 40 GHz). Occupational. CENELEC (European Committee for Electrotechnical Standardization).
- 6 EN 50385:2002. Product standard to demonstrate the compliance of radio base stations and fixed terminal stations for wireless telecommunication systems with the basic restrictions or the reference levels related to human exposure to radio frequency electromagnetic fields (110 MHz – 40 GHz). General public. CENELEC (European Committee for Electrotechnical Standardization).
- 7 EN 50401:2006. Product standard to demonstrate the compliance of fixed equipment for radio transmission (110 MHz – 40 GHz) intended for use in wireless telecommunication networks with the basic restrictions or the reference levels related to general public exposure to radio frequency electromagnetic fields, when put into service. CENELEC (European Committee for Electrotechnical Standardization).
- 8 EN 50400:2006. Basic standard to demonstrate the compliance of fixed equipment for radio transmission (110 MHz – 40 GHz) intended for use in wireless telecommunication networks with the basic restrictions or the reference levels related to general public exposure to radio frequency electromagnetic fields, when put into service. CENELEC (European Committee for Electrotechnical Standardization).
- 9 EN 50492:2008. Basic standard for the in-situ measurement of electromagnetic field strength related to human exposure in the vicinity of base stations. CENELEC (European Committee for Electrotechnical Standardization).
- 10 IEC 62232:2011. Determination of RF field strength and SAR in the vicinity of radiocommunication base stations for the purpose of evaluating human exposure. IEC (International Electrotechnical Commission).

Glossary of Terms and Acronyms

This glossary contains an alphabetical listing of terms and their definitions that are applicable to repeater products. All terms do not necessarily apply to all radios, and some terms are merely generic in nature.

Alert tone

Audio signal produced by the station, providing feedback to the user.

Analog

Refers to a continuously variable signal or a circuit or device designed to handle such signals.

ASIC

Application Specific Integrated Circuit

AUX

Auxiliary

Band

Frequencies allowed for a specific purpose.

CTCSS

Continuous Tone-Controlled Squelch Systems (PL)

Clear

Channel modulation type in which voice information is transmitted over the channel using analog modulation.

Conventional

Term used for standard non-trunked radio system (usually using TRC/DC console).

CPS

Customer Programming Software: Software with a graphical user interface containing the feature set of a radio.

Default

A pre-defined set of parameters.

Digital

Refers to data that is stored or transmitted as a sequence of discrete symbols from a finite set; most commonly this means binary data represented using electronic or electromagnetic signals.

DPL

Digital Private-Line: A type of digital communications that utilizes privacy call, as well as memory channel and busy channel lock out to enhance communication efficiency.

DSP

Digital Signal Processor, microprocessor specifically designed to perform digital signal processing algorithms.

EIA

Electronic Industries Association

ESD

Electro Static Discharge

EU

European Union

FCC

Federal Communications Commission.

FM

Frequency Modulation

Frequency

Number of times a complete electromagnetic-wave cycle occurs in a fixed unit of time (usually one second).

FRU

Field Replaceable Unit

FSK

Frequency Shift Keying

GNSS

Global Navigation Satellite System

GPIO

General Purpose Input/ Output

IC

Integrated Circuit, An assembly of interconnected components on a small semiconductor chip, usually made of silicon. One chip can contain millions of microscopic components and perform many functions.

IF

intermediate frequency

I/O

Input or Output

kHz

kilohertz: One thousand cycles per second. Used especially as a radio-frequency unit.

LCD

Liquid-Crystal Display: An LCD uses two sheets of polarizing material with a liquid-crystal solution between them. An electric current passed through the liquid causes the crystals to align so that light cannot pass through them.

LED

Light Emitting Diode: An electronic device that lights up when electricity is passed through it.

MDC

Motorola Data Communications. 1200 or 4800 baud data signalling scheme.

MHz

Megahertz: One million cycles per second. Used especially as a radio-frequency unit.

MISO

Master In, Slave Out.

MOSI

Master Out, Slave In.

PA

Power Amplifier that transmits final RF signal to transmit antenna

PC Board

Printed Circuit Board. Also referred to as a PCB.

PFC

Power Factor Correction

PL

Private-Line Tone Squelch: A continuous sub-audible tone that is transmitted along with the carrier.

Programming Cable

A cable that allows the CPS to communicate directly with the radio using RS232

PTT

Push-to-talk; the switch located on the left side of the radio which, when pressed causes the radio to transmit.

Receiver

Electronic device that amplifies RF signals. A Receiver separates the audio signal from the RF carrier, amplifies it, and converts it back to the original sound waves.

Repeater

Remote transmit/ receive facility that retransmits received signals in order to improve communications range and coverage.

RF

Radio Frequency: The portion of the electromagnetic spectrum between audio sound and infrared light (approximately 10 kHz to 10 GHz).

RSSI

Received Signal Strength Indicator; a dc voltage proportional to the received RF signal strength.

Rx

Receive.

SCM

Station Control Module; station controller.

SELV

Separated Extra Low Voltage

Signal

An electrically transmitted electromagnetic wave.

SINAD

Acronym for the ratio of signal plus noise plus distortion and noise plus distortion.

SLR

Refers to Digital Professional Repeater model names in the MOTOTRBO Professional Digital Two-Way Radio System.

Spectrum

Frequency range within which radiation has specific characteristics.

SPI

Serial Peripheral Interface (clock and data lines); simple synchronous serial interface for data transfer between processors and peripheral ICs.

Squelch

Muting of audio circuits when received signal levels fall below a pre-determined value. With carrier squelch, all channel activity that exceeds the radio's preset

Motorola Solutions Confidential

squelch level can be heard.

TOT

Time-out Timer: A timer that limits the length of a transmission.

TPL

Tone Private Line.

Transceiver

Transmitter-Receiver. A device that both transmits and receives analog or digital signals. Also abbreviated as XCVR.

Transmitter

Electronic equipment that generates and amplifies an RF carrier signal, modulates the signal, and then radiates it into space.

Trunking

Radio control system which permits efficient frequency utilization and enhanced control features.

Tx

Transmit.

UHF

Ultra High Frequency

USB

Universal Serial Bus: An external bus standard that supports data transfer rates of 12 Mbps.

VCO

Voltage-Controlled Oscillator; an oscillator whereby the frequency of oscillation can be varied by changing a control voltage.

VCTCXO

Voltage Controlled Temperature Compensated Crystal Oscillator.

VHF

Very High Frequency

VIP

Vehicle Interface Port.

VSWR

Voltage Standing Wave Ratio.

WLAN

Wireless Local Area Network



Motorola Solutions, Inc.
1303 East Algonquin Road
Schaumburg, Illinois 60196 U.S.A.

MOTOROLA, MOTO, MOTOROLA SOLUTIONS and the Stylized M logo are trademarks or registered trademarks of Motorola Trademark Holdings, LLC and are used under license. All other trademarks are the property of their respective owners.
© 2015 and 2016 Motorola Solutions, Inc. All rights reserved.
November 2016

www.motorolasolutions.com/mototrbo



MN001436A01-AB